

# KLayout-PEX Documentation

Martin Köhler

2025-03-23

## Table of contents

<b>1</b>	<b>Introduction</b>	<b>2</b>
1.1	Motivation . . . . .	2
1.2	Acknowledgements . . . . .	2
1.3	About KLayout-PEX . . . . .	2
1.4	Status . . . . .	3
1.5	Installation . . . . .	3
1.5.1	Option 1: Using IIC-OSIC-TOOLS Docker Image . . . . .	3
1.5.2	Option 2: Standalone Installation . . . . .	4
1.5.3	Useful tools: <code>meshlab</code> . . . . .	4
<b>2</b>	<b>First Steps</b>	<b>5</b>
2.1	Example Layouts . . . . .	5
2.2	Running the KPEX/FasterCap engine . . . . .	5
2.3	Running the KPEX/MAGIC engine . . . . .	7
<b>3</b>	<b>Supporting new PDKs</b>	<b>8</b>
3.1	Technology Definition Files . . . . .	8
3.2	Customized PEX-“LVS” scripts . . . . .	8
<b>4</b>	<b>KPEX/FasterCap Engine</b>	<b>10</b>
4.1	3D Input Geometries . . . . .	11
4.2	Example: MOM Capacitor . . . . .	12
4.3	Output Maxwell Capacitance Matrix . . . . .	12
<b>5</b>	<b>KPEX/MAGIC Engine</b>	<b>16</b>
5.1	MAGIC database units . . . . .	16
5.2	Types of Parasitic Capacitances . . . . .	16
5.3	Substrate Capacitance . . . . .	16
5.4	Sidewall Capacitance . . . . .	17
5.5	Overlap Capacitance . . . . .	17
5.6	Fringe Capacitance . . . . .	18
5.7	Shielding Effects . . . . .	20
5.8	Parasitic Resistance . . . . .	21
5.8.1	Wire resistance . . . . .	21
5.8.2	Via resistance . . . . .	21
<b>6</b>	<b>KPEX/2.5D Engine</b>	<b>23</b>
<b>7</b>	<b>Comparison KPEX/2.5D with MAGIC</b>	<b>24</b>
7.1	Test Pattern <code>single_plate_100um_x_100um_li1_over_substrate</code> . . . . .	24

---

7.2	Test Pattern sidewall_20um_length_distance_200nm_li1 . . . . .	26
7.3	Test Pattern sideoverlap_simple_plates_li1_m1 . . . . .	27
7.4	Test Pattern r_single_wire_li1 . . . . .	32
7.5	Test Pattern r_contact_1x1_minsize_mcon . . . . .	33
7.6	Test Pattern r_contact_2x2_minsize_mcon . . . . .	35
<b>8</b>	<b>Appendix</b>	<b>37</b>
	References . . . . .	37

# 1 Introduction

## 1.1 Motivation

In Electronic Design and Automation (EDA) for Integrated Circuits (ICs), a schematic presents an abstraction in comparison to the layout that will eventually be taped-out and fabricated by the semiconductor foundry.

While in the schematic, a connection between device terminals is seen as an equipotential, the stacked geometries in a specific layout introduce parasitic effects, which can be thought of additional resistors, capacitors (and inductors), not modeled by and missing in the original schematic.

To be able to simulate these effects, a parasitic extraction tool (PEX) is used, to extract a netlist from the layout, which represents the original schematic (created from the layout active and passive elements) augmented with the additional parasitic devices.

## 1.2 Acknowledgements

Special thanks to the public funded German project FMD-QNC (16ME0831) <https://www.elektronikforschung.de/projekte/fmd-qnc> for financial support to this work.

## 1.3 About KLayout-PEX

**KLayout** is an open source VLSI layout viewer and editor.

**KLayout-PEX** (short KPEX) is a PEX tool, well integrated with KLayout by using its API.

There are multiple PEX engines supported, currently:

- **FasterCap** integration (field solver engine)
- **MAGIC** integration (wrapper calling `magic`)
- Analytical 2.5D engine (parasitic concepts and formulas of MAGIC, implemented using KLayout methods)

### Tip

KPEX *tool* source code itself is made publicly available on GitHub ([follow this link](#)) and shared under the GPL-3.0 license.

KPEX *documentation* source code is made publicly available on GitHub ([follow this link](#)) and shared under the Apache-2.0 license.

Please feel free to create issues and/or submit pull requests on GitHub to fix errors and omissions! The production of the tool and this document would be impossible without these (and many more) great open-source software products: KLayout, FasterCap, MAGIC, protobuf, Quarto, Python, ngspice, Numpy, Scipy, Matplotlib, Git, Docker, Ubuntu, Linux...

### Caution

Currently, KPEX is developed as a Python prototype, using the [KLayout Python API](#). This allows for a faster development cycle during the current prototyping phase.

Eventually, critical parts will be re-implemented (in C++, and parallelized), to improve performance. As we're already using the KLayout API (which is pretty similar between Python, Ruby and C++), this will be relatively straight-forward.

## 1.4 Status

### Warning

Please keep in mind that this software is early stage, and not yet intended for production use.

Engine	PEX Type	Status	Description
KPEX/MAGIC	CC, RC	Usable	Wrapper engine, using installed <code>magic</code> tool
KPEX/FasterCapCC		Usable, <b>pending QA</b>	Field solver engine using <code>FasterCap</code>
KPEX/FastHenry2	R, L	Planned	Field solver engine using <code>FastHenry2</code>
KPEX/2.5D	CC	<b>Under construction</b>	Prototype engine implementing MAGIC concepts/formulas with <code>KLayout</code> means
KPEX/2.5D	R, RC	Planned	Prototype engine implementing MAGIC concepts/formulas with <code>KLayout</code> means

## 1.5 Installation

Generally, KPEX is deployed using PyPi (Python Package Index), install via:

```

1 pip3 install --upgrade klayout-pex
2
3 kpex --version # check the installed version
4 kpex --help # this will help with command line arguments

```

As for the dependencies, there are multiple options available.

### 1.5.1 Option 1: Using IIC-OSIC-TOOLS Docker Image

We provide a comprehensive, low entry barrier Docker image that comes pre-installed with most relevant open source ASIC tools, as well as the open PDKs. This is a pre-compiled Docker image which allows to do circuit design on a virtual machine on virtually any type of computing equipment (personal PC, Raspberry Pi, cloud server) on various operating systems (Windows, macOS, Linux).

For further information please look at the [Docker Hub page](#) and for detailed instructions at the [IIC-OSIC-TOOLS GitHub page](#).

### Linux

In this document, we assume that users have a basic knowledge of Linux and how to operate it using the terminal (shell). If you are not yet familiar with Linux (which is basically a must when doing integrated circuit design as many tools are only available on Linux), then please check out a Linux introductory course or tutorial online, there are many resources available.

A summary of important Linux shell commands is provided in [IIC-JKU Linux Cheatsheet](#).

### 1.5.2 Option 2: Standalone Installation

- [KLayout](#) layout tool:
  - is mandatory for all engines (besides the MAGIC-wrapper)
  - [get the latest pre-built package version](#)
  - or [follow the build instructions](#)
- [FasterCap](#) engine:
  - optional, required to run the FasterCap engine
  - either compile your own version from the [GitHub repository](#)
  - or use precompiled versions available at <https://github.com/martinjankoehler/FasterCap/releases>
- [MAGIC](#)-wrapper engine:
  - optional, required to run the MAGIC-wrapper engine
  - Follow the [installation instructions](#) at the [GitHub repository](#)
- [Skywater sky130A PDK](#):
  - optional, for now, KPEX technology specific files are deployed within the `klayout-pex` Python package
  - `pip3 install --upgrade volare` (install PDK package manager)
  - `volare ls-remote` (retrieve available PDK releases
    - \* for example `PRE-RELEASE 0c1df35fd535299ea1ef74d1e9e15dedaeb34c32 (2024.12.11)`)
  - `volare enable 0c1df35fd535299ea1ef74d1e9e15dedaeb34c32` (install a PDK version)
  - PDK files now have been installed under `$HOME/.volare/sky130A`
- [IHP SG13G2 PDK](#):
  - optional, for now, KPEX technology specific files are deployed within the `klayout-pex` Python package
  - `git clone https://github.com/IHP-GmbH/IHP-Open-PDK` (install PDK package manager)

### 1.5.3 Useful tools: meshlab

For previewing generated 3D geometries, representing the input to [FasterCap](#), we recommend installing [MeshLab](#). The generated STL-files are located at `output/<design>/Geometries/*.stl`.

## 2 First Steps

- The command line tool `kpex` is used to trigger the parasitic extraction flow from the terminal.
- Get help calling `kpex --help`.

### 2.1 Example Layouts

Example layouts are included in the `testdata/designs` subdirectory of the KLayout-PEX source code:

```

1 git clone https://github.com/martinjankoehler/klayout-pex.git
2
3 # for sky130A
4 find testdata/designs/sky130A -name "*.gds.gz"
5
6 # for IHP SG13G2
7 find testdata/designs/ihp_sg13g2 -name "*.gds.gz"

```

### 2.2 Running the KPEX/FasterCap engine

Preconditions:

- `klayout-pex` was installed, see Section 1.5
- `FasterCap` was installed, see Section 1.5

#### **i** Note

Normally, devices with SPICE (Nagel 1975) simulation models (e.g. like MOM-capacitors<sup>1</sup> in the sky130A PDK) are ignored (“blackboxed”) during parasitic extraction. `kpex` has an option `--blacklist n` to allow extraction of those devices (whiteboxing), which can be useful during development (during the prototype phase, whiteboxing is actually the default setting, so please use `--blacklist y` to explicitly configure blackboxing).

Let’s try the following:

```

1 kpex --pdk sky130A --blackbox n --gds \
2 testdata/designs/sky130A/*/cap_vpp_04p4x04p6_11m1m2_noshield.gds.gz

```

#### **i** Note

This will report an error that we have not activated one or more engines, and list the available engines:

Argument	Description
<code>--fastercap</code>	Run <code>kpex/FasterCap</code> engine
<code>--2.5D</code>	Run <code>kpex/2.5D</code> engine
<code>--magic</code>	Run <code>MAGIC</code> engine

Now, to run the `FasterCap` engine (might take a couple of minutes):

<sup>1</sup>Metal-Oxide-Metal capacitors

```

1 kpex --pdk sky130A --blackbox n --fastercap --gds \
2 testdata/designs/sky130A/*/cap_vpp_04p4x04p6_11m1m2_noshield.gds.gz

```

Within the output directory (defaults to `output`), KPEX creates a subdirectory `Geometries`, containing STL-files that provide a preview of the FasterCap input geometries. Use MeshLab (see Section 1.5.3) to open and preview those files:

```
1 ls -d output/cap_vpp_04*/Geometries/*.stl
```

### Tip

- Open the `*.stl` files in MeshLab
- Use the eye buttons to hide and show each file/mesh
- Use the align tool (“A” in the toolbar) to assign different colors
- Start by showing only on the conductors (files named `cond_*.stl`)
- Then try showing different dielectrics (files named `diel_*.stl`), to see how they surround the conductors.

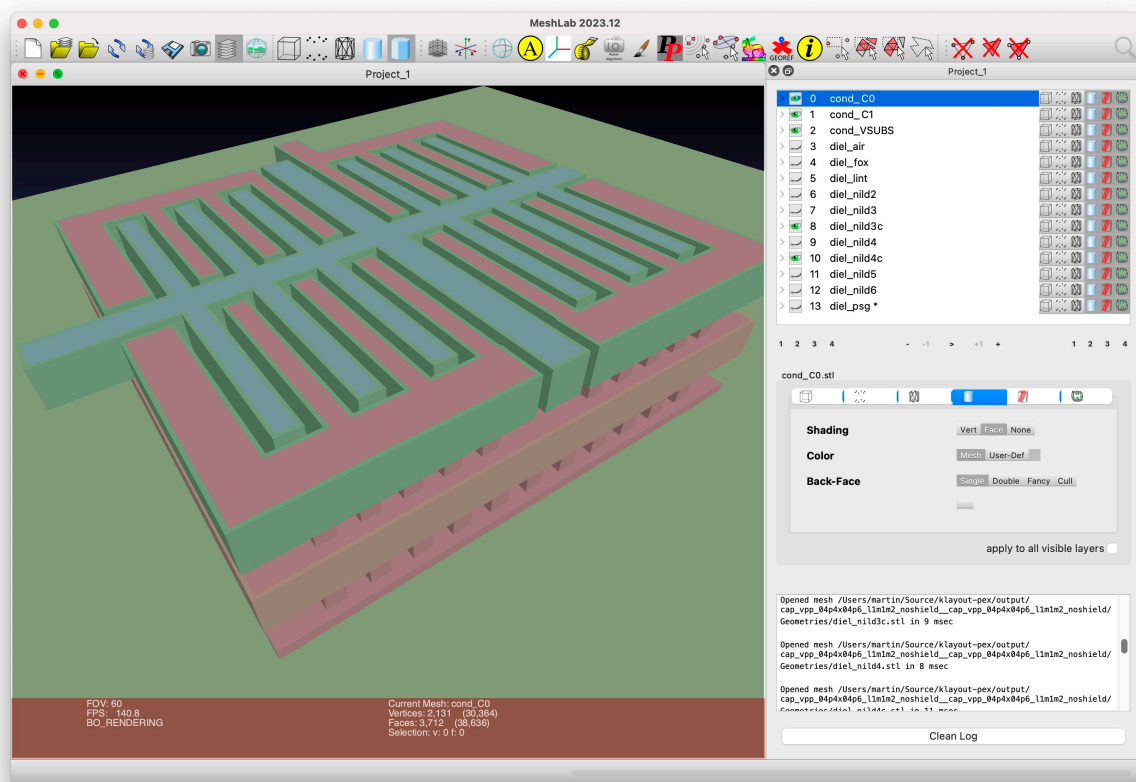

In the log file, we see the output of FasterCap including the Maxwell capacitance matrix:

Capacitance matrix is:

Dimension 3 x 3

```

g1_VSUBS  5.2959e-09 -4.46971e-10 -1.67304e-09
g2_C1     -5.56106e-10 1.5383e-08 -1.47213e-08
g3_C0     -1.69838e-09 -1.48846e-08 1.64502e-08

```

KPEX interprets this matrix and prints a CSV netlist, which can be pasted into a spreadsheet application:

```
1 Device;Net1;Net2;Capacitance [fF]
2 Cext_0_1;VSUBS;C1;0.5
3 Cext_0_2;VSUBS;C0;1.69
4 Cext_1_2;C1;C0;14.8
5 Cext_1_1;C1;VSUBS;0.08
```

In addition, a SPICE netlist is generated.

## 2.3 Running the KPEX/MAGIC engine

Preconditions:

- `klayout-pex` was installed, see Section 1.5
- `magic` was installed, see Section 1.5

The `magic` section of `kpex --help` describes the arguments and their defaults. Important arguments:

- `--magicrc`: specify location of the `magicrc` file
- `--gds`: path to the GDS input layout
- `--magic`: enable magic engine

```
1 kpex --pdk sky130A --magic --gds \  
2 testdata/designs/sky130A/*/cap_vpp_04p4x04p6_11m1m2_noshield.gds.gz
```



## 3 Supporting new PDKs

For every supported PDK, a KPEX technology definition is required, as well as customized PEX-“LVS” scripts.

### 3.1 Technology Definition Files

The KPEX technology definition format uses [Google Protocol Buffers](#), so there is:

- formal schema files, defining the structure and data types involved
  - [protos/tech.proto](#): main schema / entry point, includes the others
  - [protos/process\\_stack.proto](#): describes details of the process stack, such as dielectrics and heights of layers
  - [protos/process\\_parasitics.proto](#): parasitic tables, used to parametrize the 2.5D engine
- multiple concrete instantiations, that adhere to this schema (called *messages* in the `protobuf` lingo)
  - in the form of JSON files
  - Skywater 130A: `klayout_pex_protobuf/sky130A_tech.pb.json`
  - IHP SG13G2: `klayout_pex_protobuf/ihp_sg13g2_tech.pb.json`

#### **i** Note

The built-in JSON tech files are programmatically generated during the build process<sup>2</sup>. Therefore they are not part of the repository source code, but of course part of the deployed Python wheels. To review those, look into your Python `site-packages`<sup>3</sup>/`klayout_pex_protobuf`.

### 3.2 Customized PEX-“LVS” scripts

KLayout has built-in support for Layout-Versus-Schematic (LVS) scripts, based on its Ruby API. Customized “LVS” scripts are (“ab”)used in KPEX, not with the intent of comparing Layout-Versus-Schematic, but rather to extract the connectivity/net information for all polygons across multiple layers. The resulting net information is stored in a KLayout LVS Database (“LVSDB”).

<sup>2</sup>C++ generator scripts the built-in tech files are located in `cxx/gen_tech_pb/pdk/*.cpp`.

<sup>3</sup>To find the `site-packages` directory for the `klayout-pex` package, call `pip3 show klayout-pex`.

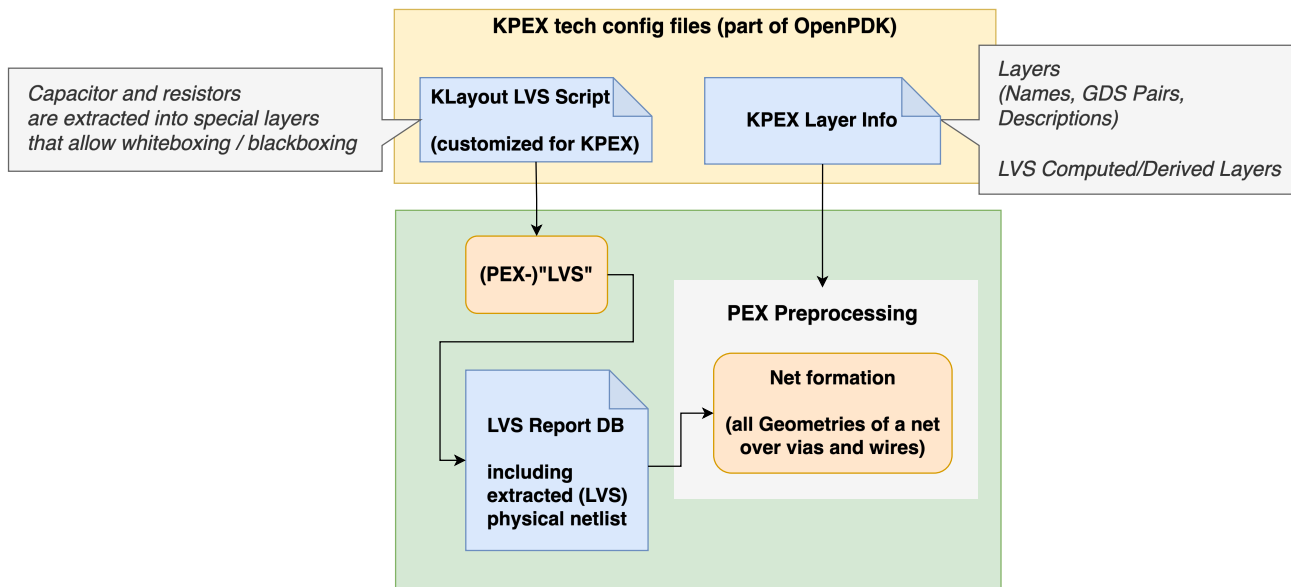

Figure 1: KPEX Net Formation

These customized “LVS” scripts are stored in:

- Skywater sky130A: [pdk/sky130A/libs.tech/kpex/sky130.lvs](#)
- IHP SG13G2: [pdk/ihp\\_sg13gs/libs.tech/kpex/sg13g2.lvs](#)

What’s specific about this customization:

- Layers names must be assigned, using KLayout’s `(name(layer, name))` function
- MOM<sup>4</sup> capacitors, MIM<sup>5</sup> capacitors and resistors should be extracted to separate layers, to enable blackboxing / whiteboxing.

The layer names in the script must correspond with the names configured in the tech JSON file.

<sup>4</sup>Metal-Oxide-Metal capacitors

<sup>5</sup>Metal-Insulator-Metal capacitors

## 4 KPEX/FasterCap Engine

FasterCap is a 3D and 2D parallel capacitance field solver, inspired by FastCap2. <https://www.fastfieldsolvers.com/fastercap.htm>

Starting from an input layout (e.g. GDS file) and a process stack-up (part of the Section 3.1), KPEX creates input geometries for FasterCap. After running FasterCap, the Maxwell capacitance matrix is parsed and interpreted to obtain the parasitic capacitances.

See Section 2.2 to get started with a first extraction example.

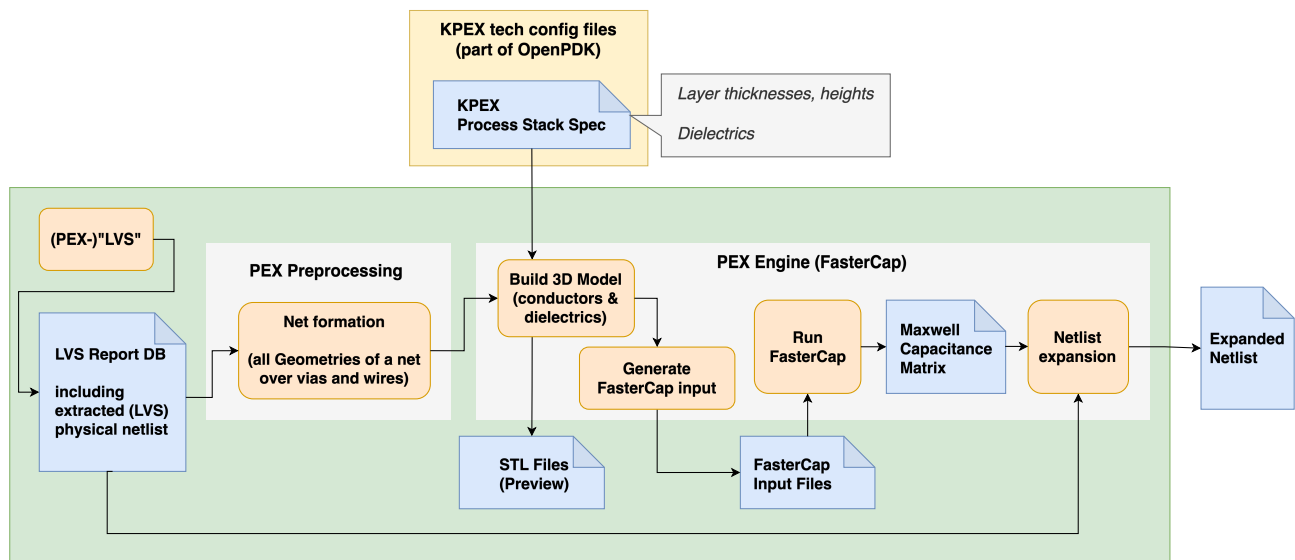

Figure 2: KPEX/FasterCap Engine

## 4.1 3D Input Geometries

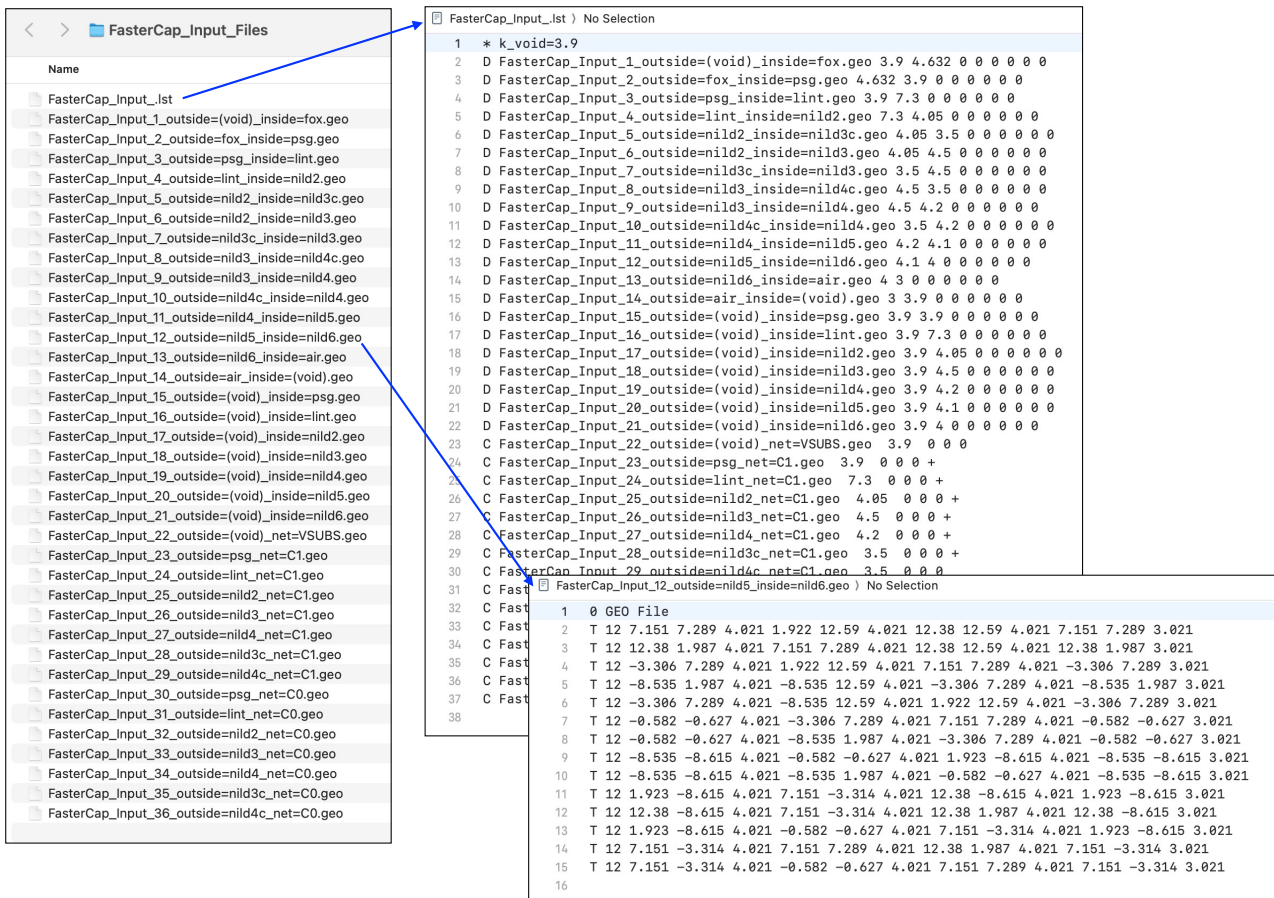

Figure 3: FasterCap 3D Input: File System Overview

The FasterCap input files and their format is documented in (Di Lorenzo 2019), a PDF version of the Windows-specific \*.chm file is available at <https://github.com/martinjankoebler/FasterCap/tree/master/doc/pdf>.

KPEX generates 3D input geometries:

- \*.lst file: Main input file
  - defines dielectric instances
  - defines conductor instances
  - each instance refers to a \*.geo file
- \*.geo files: Defines single geometry
  - defines shapes (e.g. triangles)
  - Each shape has a reference point to define inside/outside

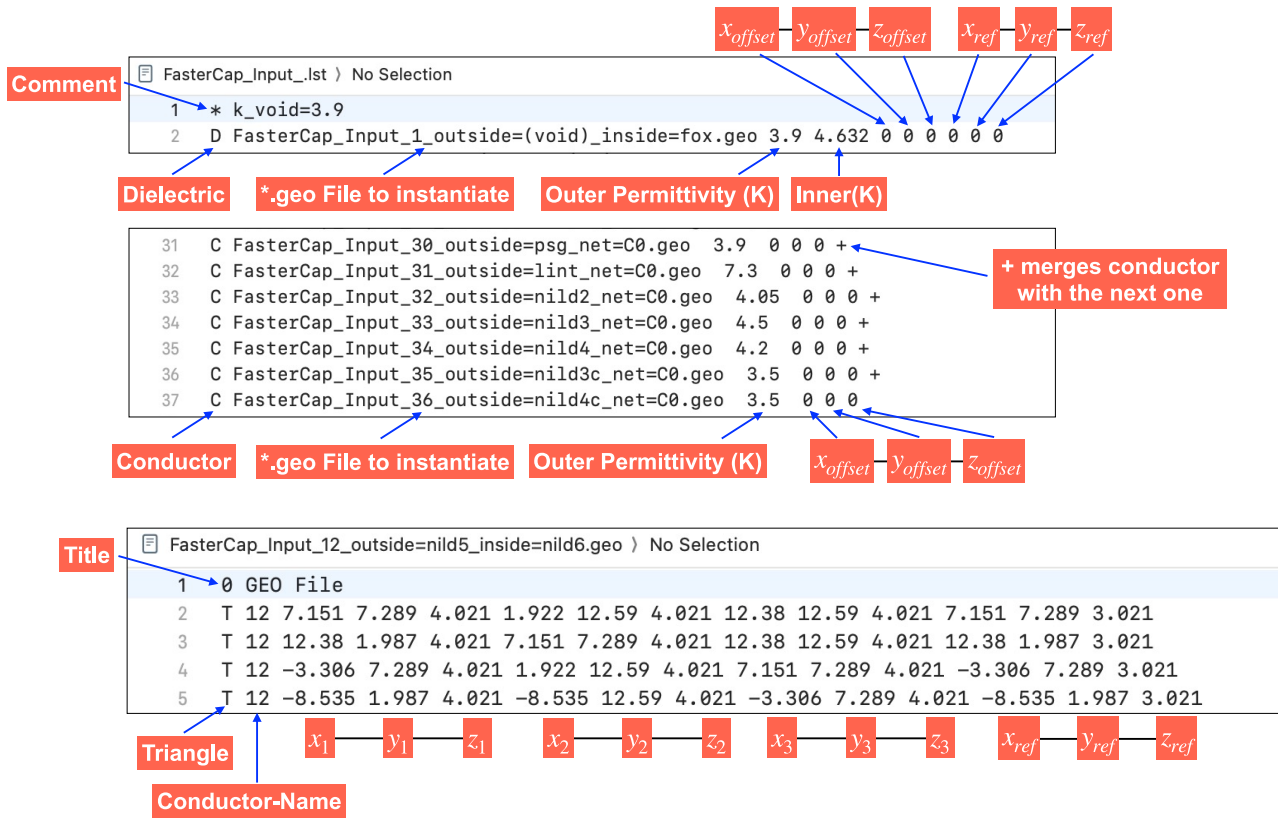

Figure 4: FasterCap 3D Input: File Format

## 4.2 Example: MOM Capacitor

Figure 5 depicts the MOM capacitor example of a from Section 2.2).

The corresponding schematic representation of Figure 6 contains 3 conductors ( $N_1$ ,  $N_2$  and  $N_3$ ), and coupling capacitances:

- Capacitances between conductors:  $C_{ij}$  where  $i \neq j$ 
  - $C_{23}$  is the capacitance “intended” by the MOM designer
- Capacitances between conductors and ground:  $C_{ii}$

## 4.3 Output Maxwell Capacitance Matrix

A Maxwell capacitance matrix (Maxwell 1873) provides the relation between voltages on a set of conductors and the charges on these conductors, as described by the FasterCap author in the white paper (Di Lorenzo 2023).

FasterCap log output prints the Maxwell capacitance matrix (one for each iteration/refinement).

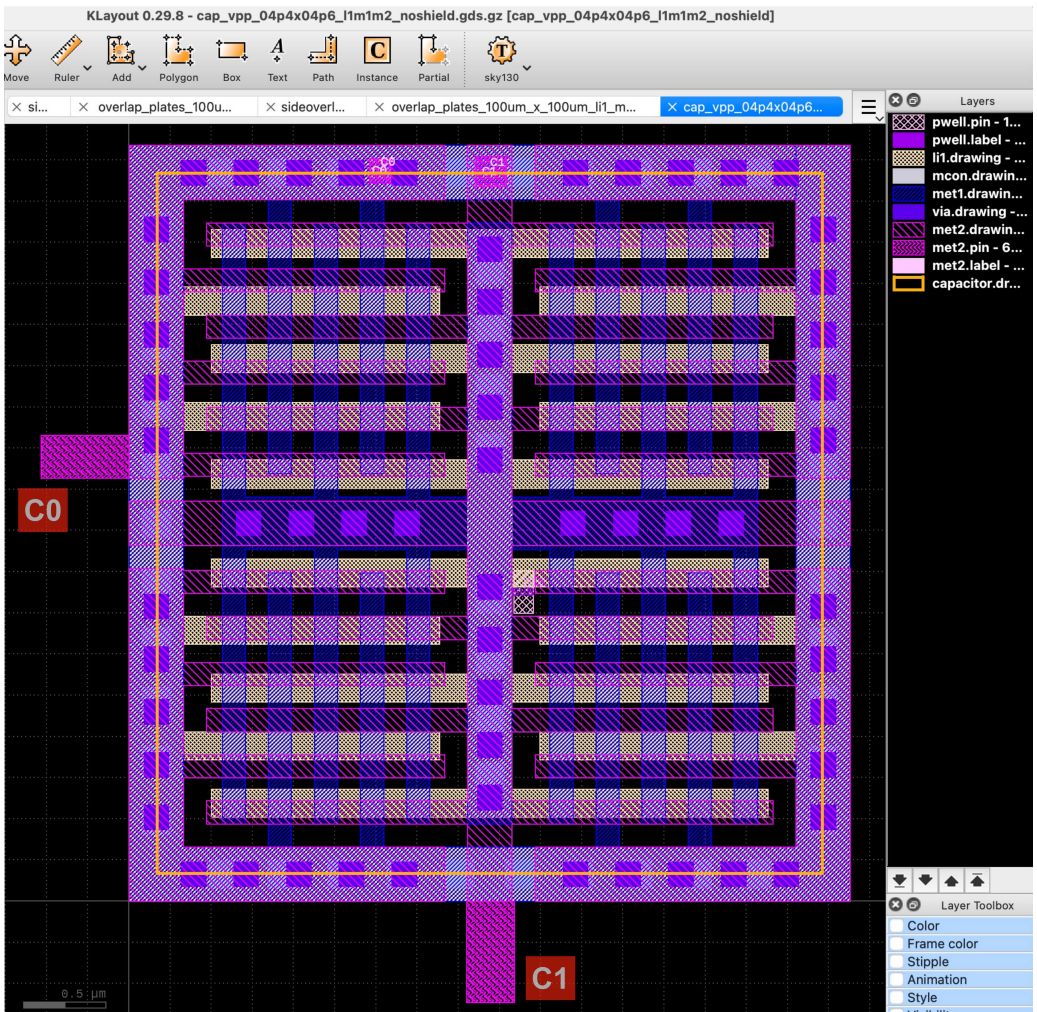

(a) MOM Capacitor: GDS Layout

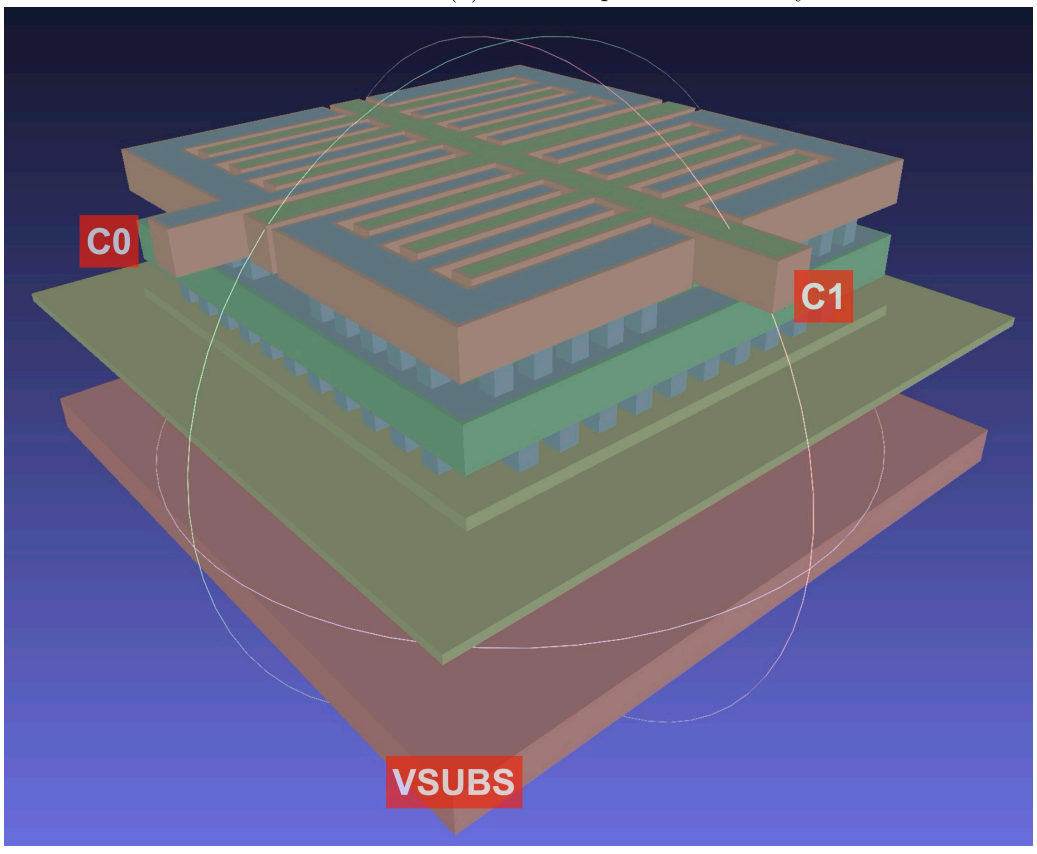

(b) MOM Capacitor: MeshLab 3D Preview

Figure 5: MOM Capacitor

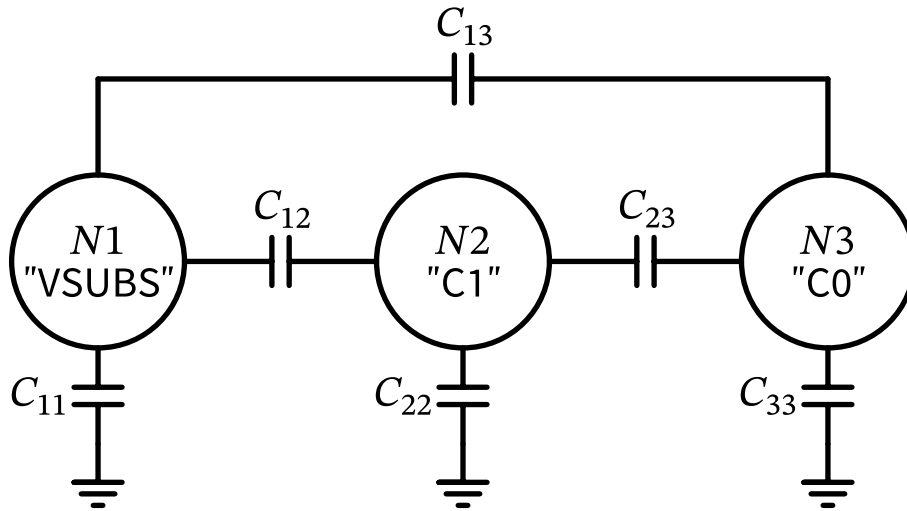

Figure 6: Schematic representation of the MOM capacitor.

```

Capacitance matrix is:
Dimension 3 x 3
g1_VSUBS  2.08888e-09 -1.46568e-10 -7.37007e-10
g2_C1    -1.64457e-10 1.47687e-08 -1.44368e-08
g3_C0    -7.68811e-10 -1.4528e-08 1.54806e-08

Weighted Frobenius norm of the difference between capacitance (auto option): 0.005031

Solve statistics:
Number of input panels: 18819 of which 5856 conductors and 12963 dielectric
Number of input panels to solver engine: 18819
Number of panels after refinement: 47371
Number of potential estimates: 6249961
Number of links: 19880193 (uncompressed 2244011641, compression ratio is 99.1%)
Max recursion level: 35
Max Mesh relative refinement value: 0.00126534
Time for reading input file: 0.014353s
Time for building super hierarchy: 0.001892s
Time for discretization: 0.562416s
Time for building potential matrix: 0.673007s
Time for precond calculation: 0.251937s
Time for gmres solving: 20.033398s

```

Figure 7: FasterCap Log Output: Maxwell Capacitance Matrix

- Matrix Properties:

- Scaling: units have to be divided by  $10^{-6}$
- rows and columns are the same (list of net names)
- Row Cells:
  - \* off diagonals cells contains the coupling between row/col nets (times  $-1$ )
  - \* diagonal cells contains the sum of the absolute values of all other cells in the row
- Matrix Symmetry:
  - \* in theory (ideal world), the matrix would be symmetric
  - \* in practice it's not
  - \* therefore FastCap2 did average the off-diagonals
  - \* FasterCap does not average, so it's done as part of KPEX

$$C_{3 \times 3} = \begin{bmatrix} \text{VSUBS} & \text{C0} & \text{C1} \\ c_{11} + c_{12} + c_{13} & -c_{12} & -c_{13} \\ -c_{21} & c_{22} + c_{22} + c_{23} & -c_{23} \\ -c_{31} & -c_{32} & c_{31} + c_{32} + c_{33} \end{bmatrix} \begin{bmatrix} \text{VSUBS} \\ \text{C0} \\ \text{C1} \end{bmatrix}$$

$$C_{avg} = \begin{bmatrix} c_{11} - |\text{avg}(c_{12}, c_{21})| - |\text{avg}(c_{13}, c_{31})| & |\text{avg}(c_{12}, c_{21})| & |\text{avg}(c_{13}, c_{31})| \\ |\text{avg}(c_{12}, c_{21})| & c_{22} - |\text{avg}(c_{12}, c_{21})| - |\text{avg}(c_{23}, c_{32})| & |\text{avg}(c_{23}, c_{32})| \\ |\text{avg}(c_{13}, c_{31})| & |\text{avg}(c_{23}, c_{32})| & c_{33} - |\text{avg}(c_{13}, c_{31})| - |\text{avg}(c_{23}, c_{32})| \end{bmatrix}$$

$$C_{femtofarad} = \begin{bmatrix} 2.09 - \text{avg}(0.147, 0.164) - \text{avg}(0.74, 0.77) & \text{avg}(0.147, 0.164) & \text{avg}(0.74, 0.77) \\ \text{avg}(0.147, 0.164) & 14.77 - \text{avg}(0.147, 0.164) - \text{avg}(14.44, 14.52) & \text{avg}(14.44, 14.52) \\ \text{avg}(0.74, 0.77) & \text{avg}(14.44, 14.52) & 15.48 - \text{avg}(0.74, 0.77) - \text{avg}(14.44, 14.52) \end{bmatrix}$$

$$= \begin{bmatrix} 1.18 & 0.16 & 0.75 \\ 0.16 & 0.13 & 14.48 \\ 0.75 & 14.48 & 0.25 \end{bmatrix}$$

### Result CSV

Device	Net1	Net2	Capacitance [F]	Capacitance [fF]
Cext_0_1	VSUBS	C1	1.555125e-16	0.16f
Cext_0_2	VSUBS	C0	7.52909e-16	0.75f
Cext_1_2	C1	C0	1.44824e-14	14.48f
Cext_1_1	C1	VSUBS	1.307875e-16	0.13f
Cext_2_2	C0	VSUBS	2.45291e-16	0.25f

Figure 8: FasterCap Maxwell Capacitance Matrix: Interpretation



## 5 KPEX/MAGIC Engine

This engine is merely just a wrapper around `magic`, which prepares a TCL script that opens the layout file and starts MAGIC's PEX flow. See Section 2.3 to get started with a first extraction example.

The following chapter will illustrate concepts of the parasitic extraction done in MAGIC, also motivated by the fact that the engine in Section 6 will be based on those. Major parts of this illustration, the figures and concepts are based on work done by MAGIC maintainer Tim Edwards, especially his talk from FSiC conference 2022 (Edwards 2022) and a (conceptual follow-up) ChipsAlliance meeting on April 4, 2023, see (Edwards 2023b) and (Edwards 2023a). In addition, code review and debugging of the MAGIC codebase was performed.

### 5.1 MAGIC database units

- To convert between MAGIC database units and  $\mu m$ , a scaling factor  $\alpha$  is used, so that  $L_{\mu m} = \frac{L_{dbu}}{\alpha}$
- E.g. for sky130A,  $\alpha = 200.0$

### 5.2 Types of Parasitic Capacitances

MAGIC models multiple types of capacitances:

- *Substrate Overlap*: Overlap area of a metal with the substrate
- *Substrate Fringing*: Sidewall of a metal fringes out to substrate
- *Sidewall Capacitance*: Coupling between adjacent sidewalls on the same layer
- *Overlap Capacitance*: Overlap on different metal layers
- *Fringe Capacitance* (“*Side Overlap*”): Sidewall of a metal fringes out other metal layers

### 5.3 Substrate Capacitance

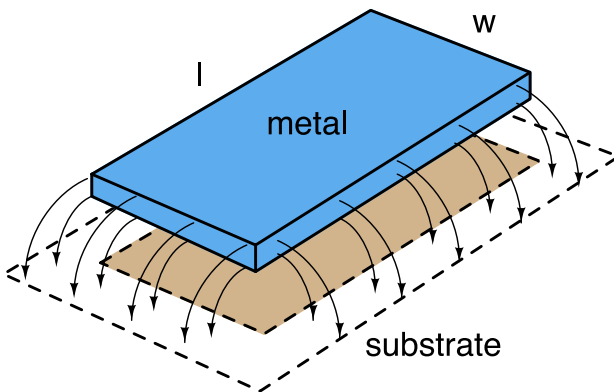

- Overlapping area:

$$C_{area} = \frac{\epsilon_{si} * K}{d} * area \quad \left[ \frac{F}{\mu m^2} * \mu m^2 \right]$$

- Fringe (“Perimeter”):

$$C_{fringe\ to\ substrate} = perimeter * C_{perim} = (2l + 2w) * C_{perim}$$

- Coefficients like  $C_{perim}$  are part of the tech files (Parasitic Tables)

## 5.4 Sidewall Capacitance

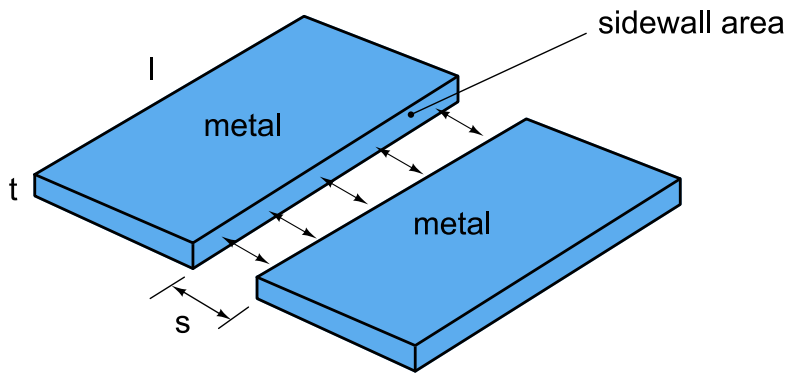

$$\begin{aligned}
 C_{sidewall} &= \frac{\epsilon_{si} * K}{s} * \text{sidewall area} \quad \left[ \frac{F}{\mu m^2} * \mu m^2 \right] \\
 &= \frac{\epsilon_{si} * K}{s} * t * l \quad \left[ \frac{F}{\mu m^2} * \mu m * \mu m \right] \\
 C_{sidewall} &= \frac{C_{sidewall\ coeff}}{s} * l \quad \left[ \frac{F}{\mu m} * \mu m \right]
 \end{aligned}$$

- Coefficients are part of the tech files (Parasitic Tables)
- Layer thickness  $t$  is normally multiplied into the coefficient
- Foundry tables give constant coefficient referenced to  $s = 1$

## 5.5 Overlap Capacitance

- Overlapping area:

$$C_{area} = \frac{\epsilon_{si} * K}{d} * \text{area} \quad \left[ \frac{F}{\mu m^2} * \mu m^2 \right]$$

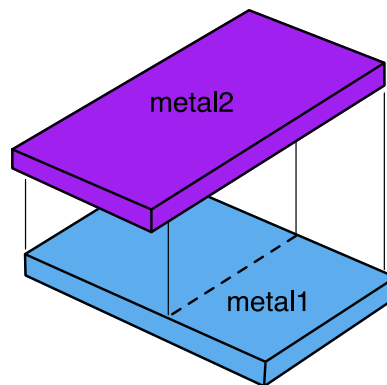

Figure 9: Overlap Capacitance

## 5.6 Fringe Capacitance

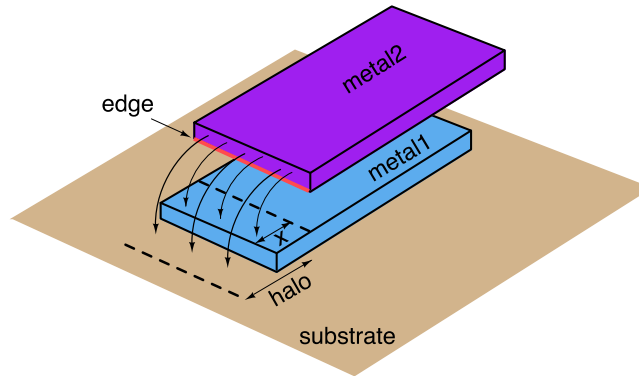

Figure 10: Fringe Capacitance: Overlapping (1)

- Causing sidewall (its bottom edge depicted red)
- Assume: Field is bounded by fringe halo (e.g.  $8\ \mu\text{m}$  away from edge)
- Fractions of fringe goes to metal1 or substrate

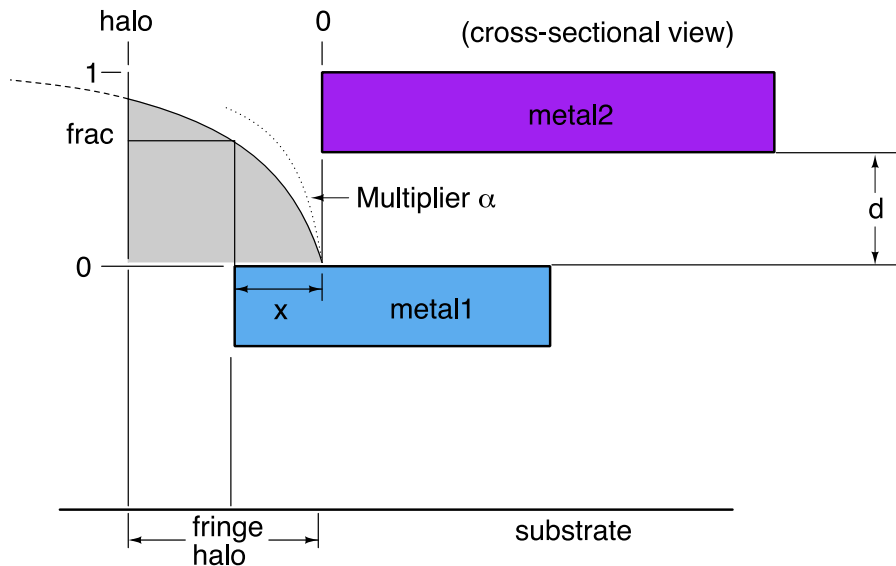

Figure 11: Fringe Capacitance: Overlapping (2)

- Multiplier  $\alpha$  (comes from tech files: overlap table)
  - determines how quickly fringe capacitance drops with increasing distance
  - $\alpha$  is related to distance  $d$  between layers
  - $\alpha$  is proportional to  $C_{overlap_{metal1 \leftrightarrow metal2}} = \frac{\epsilon_{si} * K}{d} * \text{area}$   
(for fixed value of area  $1\ \mu\text{m}^2$ )
- Fringe Fractions:
  - $\text{frac}_{metal1} = \frac{2}{\pi} * \text{atan}(\alpha_{metal2 \rightarrow metal1} * x)$
  - $\text{frac}_{sub} = \frac{2}{\pi} * \text{atan}(\alpha_{metal2 \rightarrow sub} * (\text{halo} - x))$
  - $\frac{2}{\pi}$  is multiplied because of scaling to interval  $[0.0, 1.0]$ , as  $\text{atan}(\infty) = \frac{\pi}{2}$
- Overlap capacitance:
  - $C_{overlap} = \frac{\epsilon_{si} * K}{d} * \text{area}$  (with area =  $1\ \mu\text{m}^2$ )
- Coupling capacitance  $metal1 \leftrightarrow metal2$ :

- $\alpha_{metal1 \leftrightarrow metal2} = \alpha_{scalefac} * C_{overlap_{metal1 \leftrightarrow metal2}}$
- $frac_{metal1} = \frac{2}{\pi} * \text{atan}(\alpha_{metal1 \leftrightarrow metal2} * x)$
- effective length = edge length \*  $frac_{metal1}$
- $C_{fringe_{metal2 \rightarrow metal1}} = \text{effective length} * C_{sideoverlap_{metal2 \rightarrow metal1}}$

- Coupling capacitance  $metal1 \leftrightarrow sub$ :

- $\alpha_{metal1 \leftrightarrow sub} = \alpha_{scalefac} * C_{overlap_{metal1 \leftrightarrow sub}}$
- $frac_{sub} = \frac{2}{\pi} * \text{atan}(\alpha_{metal1 \leftrightarrow sub} * (\text{halo} - x))$
- effective length = edge length \*  $frac_{sub}$
- $C_{fringe_{metal2 \rightarrow sub}} = \text{effective length} * C_{sideoverlap_{metal2 \rightarrow sub}}$

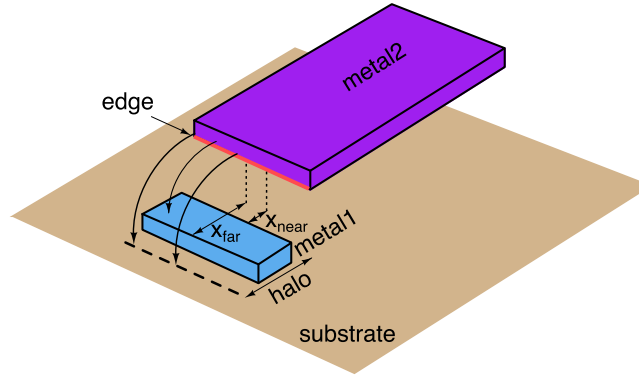

Figure 12: Fringe Capacitance: Non Overlapping (1)

- Partial side overlap

- In case there is only a partial side overlap, the non-existing near fraction is subtracted from the far fraction
- $metal1$  wire is offset, starts at  $x_{near}$
- $metal1$  ends at  $x_{far}$

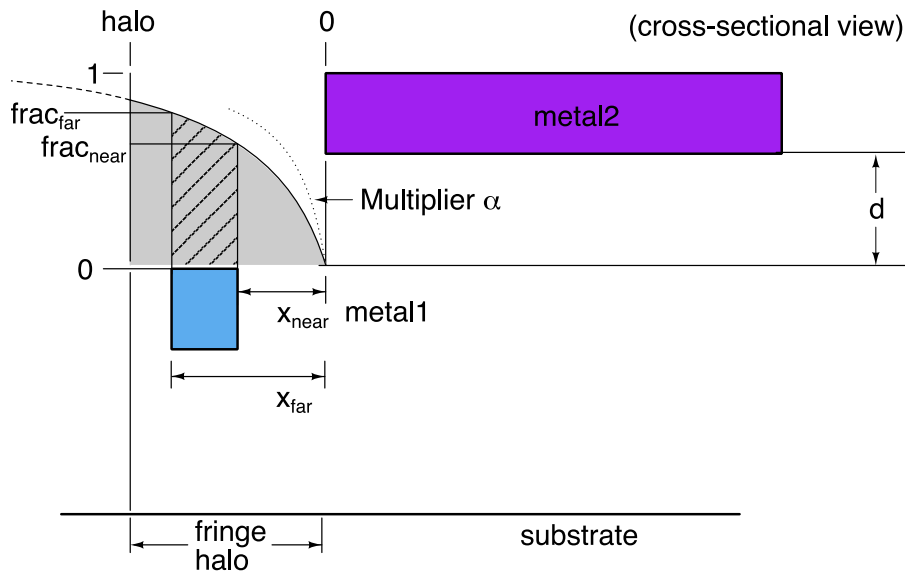

Figure 13: Fringe Capacitance: Non Overlapping (2)

- $frac_{near} = \frac{2}{\pi} * \text{atan}(\alpha * x_{near})$
- $frac_{far} = \frac{2}{\pi} * \text{atan}(\alpha * x_{far})$
- $frac = frac_{far} - frac_{near}$

### 5.7 Shielding Effects

Table 3: Shielding effects

Type	Shielding		
	To Substrate	Between layers	On same layer
Overlap shielding	✓	✓	✗
Sidewall shielding	✗	✗	✓
Lateral fringe shielding	✗	✓	✓
Vertical fringe shielding	✓	✓	✗

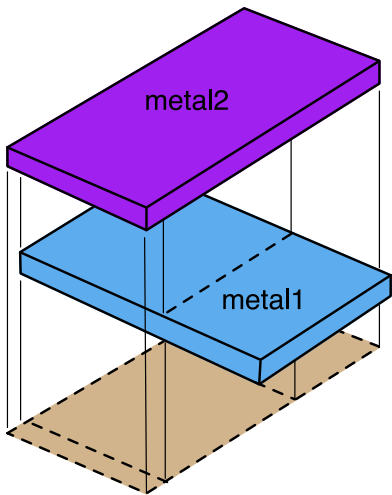

(a) Overlap shielding

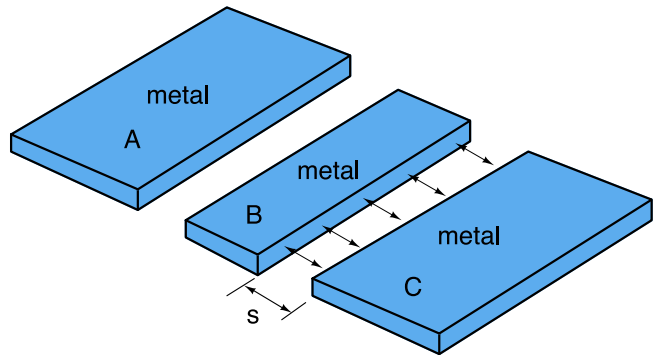

(b) Sidewall shielding

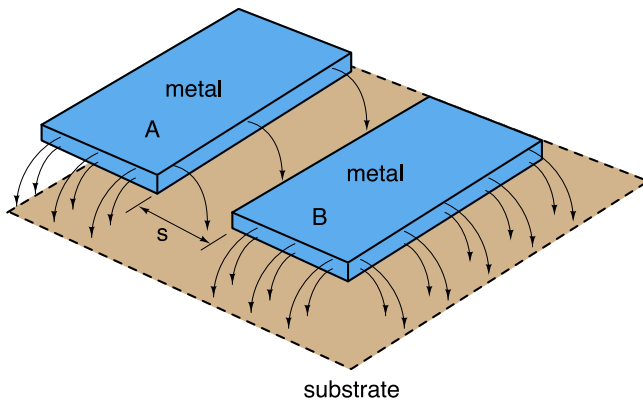

(c) Lateral fringe shielding (1/2)

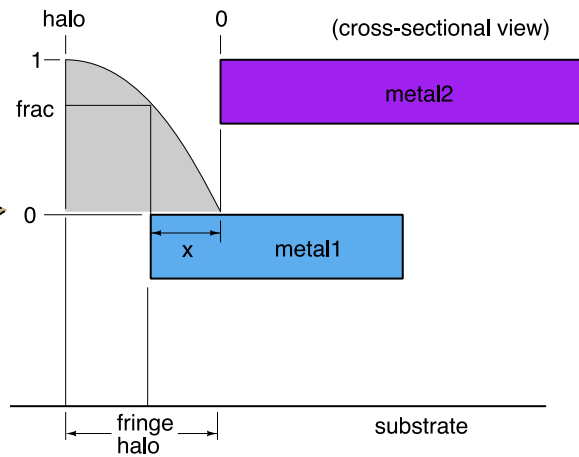

(d) Vertical fringe shielding

Figure 14: Shielding Effects

Note, given an analyzed sidewall (edge in 2D), lateral fringe shielding

- is caused by opposing shapes on the same layer
  - even by the same polygon
  - by other polygons (same net)
  - by other polygons (different net) — this is what we also look at when analyzing sidewall coupling
- will shield the fringing to the lower layers, i.e. in Figure 15 the coupling between the two shapes is the same in the above and below cases

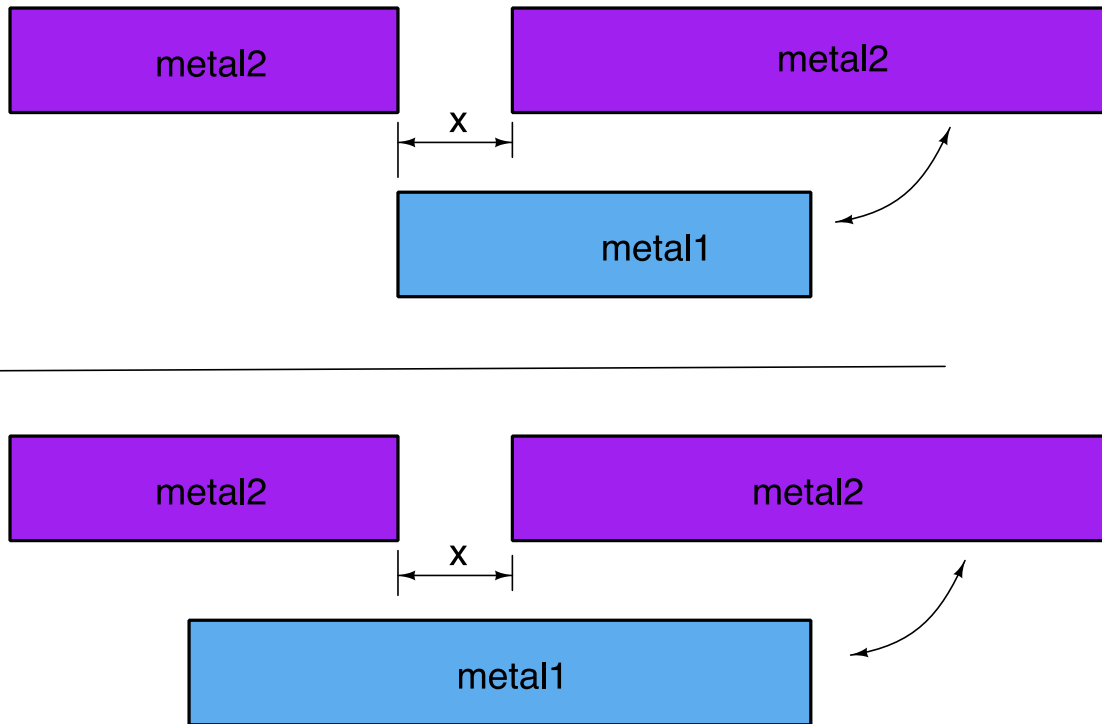

Figure 15: Lateral fringe shielding (2/2)

## 5.8 Parasitic Resistance

Magic constructs a graph of resistors between nodes

- device terminals
- pins
- junctions

### 5.8.1 Wire resistance

- Given a wire with length  $l$  and height  $h$ , the basic formula is

$$R_{wire} = \frac{l}{h} * R_{coeff} \quad \left[ \frac{\mu m}{\mu m} * m\Omega \right]$$

- Coefficient  $R_{coeff}$  is part of the tech files (Parasitic Tables)
  - defined for every metal layer
  - in  $m\Omega$  for  $1 \mu m^2$
  - Coefficient already includes the thickness aspect of the layer, so the formula works in 2D

### 5.8.2 Via resistance

- Given
  - drawn via in the layout, with width  $w$  and height  $h$
  - design rules defined for each via layer:
    - \* via width  $viawidth$

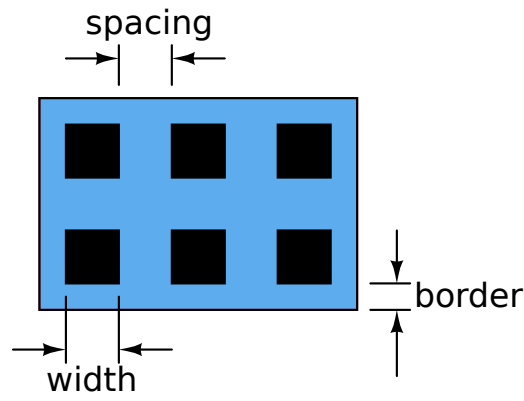

Figure 16: Via dimensions)

- \* *spacing* between vias (in case of a via array)
- \* *border* on each side of the via

- MAGIC interpretation of the via drawing

- determine number of vias in  $x$  and  $y$  direction, i.e.  $n_x$  and  $n_y$
- if  $x$  and  $y$  dimensions are below the minimum size, MAGIC counts 1 via in each direction
- if the dimensions are larger, we calculate how much vias fit

$$R_{via} = \frac{R_{coeff}}{n_x * n_y} \left[ \frac{m\Omega}{\text{via count}} \right]$$

$$n_x = 1 + \left\lfloor \frac{w - (viawidth + 2 * border)}{viawidth + spacing} \right\rfloor$$

$$n_y = 1 + \left\lfloor \frac{h - (viawidth + 2 * border)}{viawidth + spacing} \right\rfloor$$

- Coefficient  $R_{coeff}$  is part of the tech files (Parasitic Tables)

- defined for every via layer
- in  $m\Omega$  per via
- Coefficient already includes the thickness aspect of the layer, so the formula works in 2D

## 6 KPEX/2.5D Engine

Field solvers are precise, yet slow, they are useful to obtain a golden reference.

For most use cases, a faster engine is desirable-. KPEX/MAGIC is such an engine, but the MAGIC code is tightly coupled with the database, layer/via design choices, and user interface of MAGIC. For example, it runs single-threaded.

Therefore, the KPEX 2.5D Engine intends to implement the concepts and formulas of MAGIC (see Section 5.2), but in a way that is best suited to the KLayout API.

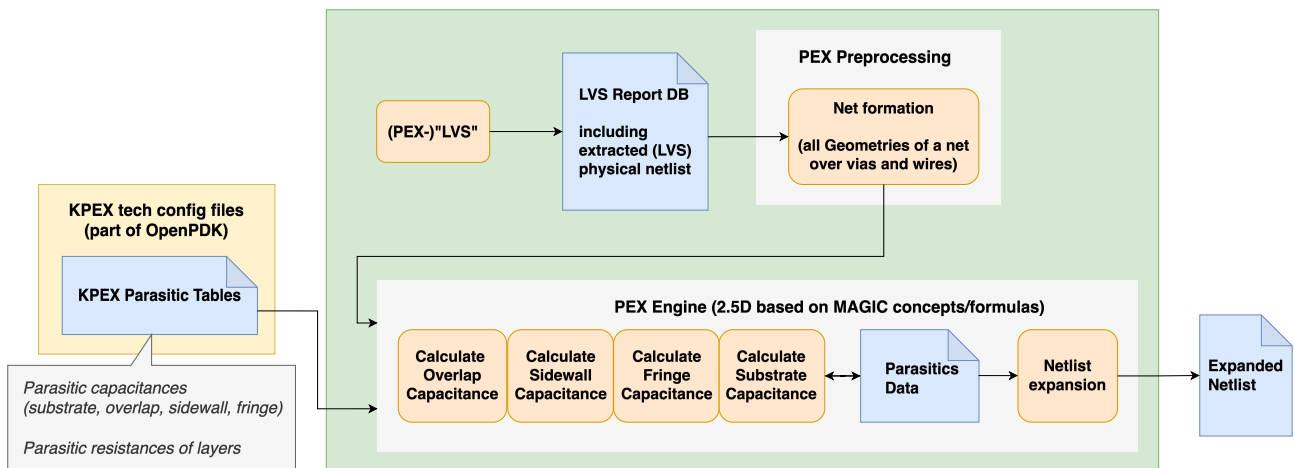

Figure 17: KPEX 2.5D Engine

### Caution

This section is under heavy construction!





## 7 Comparison KPEX/2.5D with MAGIC

The initial goal of KPEX/2.5D is to basically come up with the same results as KPEX/MAGIC.

### **i** Note

Notes about this comparison:

- Version Magic 8.3 rev 486 is used, but augmented with debug logging<sup>6</sup>, which will be shown and discussed for each example.
- KPEX/MAGIC halo is set to `--magic_halo=100000`
  - NOTE: the screenshots however were created with `--magic_halo=8` to give better illustrations
- KPEX/2.5D halo is set to `--halo=100000`

### 7.1 Test Pattern `single_plate_100um_x_100um_li1_over_substrate`

GDS: [https://github.com/martinjankoehler/klayout-pex/blob/main/testdata/designs/sky130A/test\\_patterns/single\\_plate\\_100um\\_x\\_100um\\_li1\\_over\\_substrate.gds.gz](https://github.com/martinjankoehler/klayout-pex/blob/main/testdata/designs/sky130A/test_patterns/single_plate_100um_x_100um_li1_over_substrate.gds.gz)

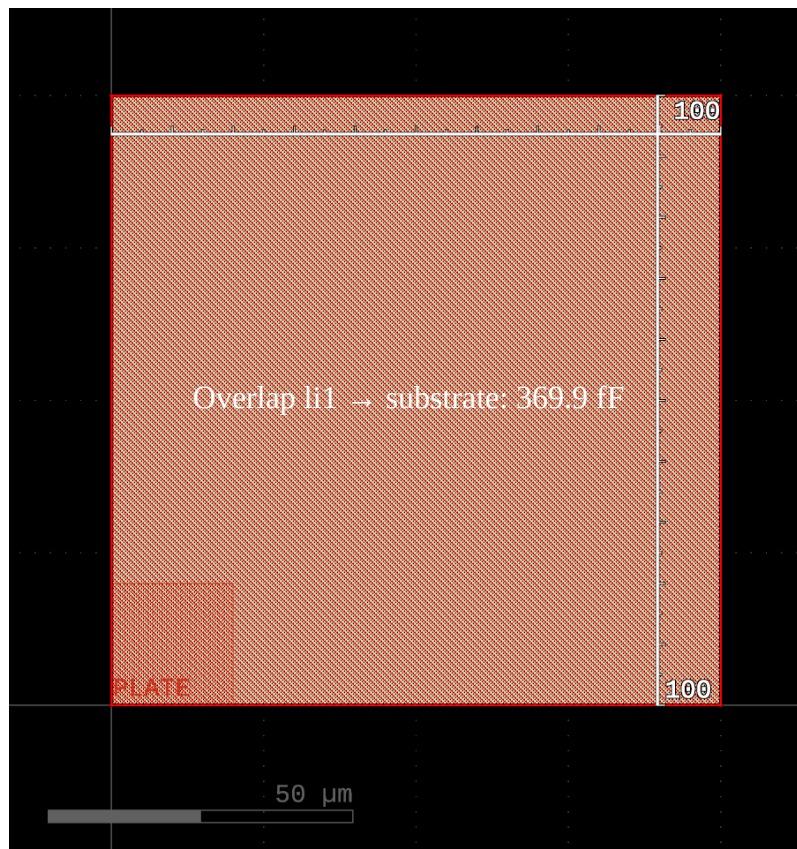

Figure 18: Overlap capacitance li1 to substrate.

<sup>6</sup>A fork of MAGIC which includes debug logging about the different parasitic contributions is hosted here: <https://github.com/martinjankoehler/magic>

Table 4: Extracted Parasitic Overlap Capacitances

Description	Layer Top	Net Top	Layer Bottom	Net Bottom	MAGIC [fF]	KPEX/2.5D [fF]	MAGIC Lines
Overlap	li1	li1	substrate	VSUBS	369.9	369.9	4

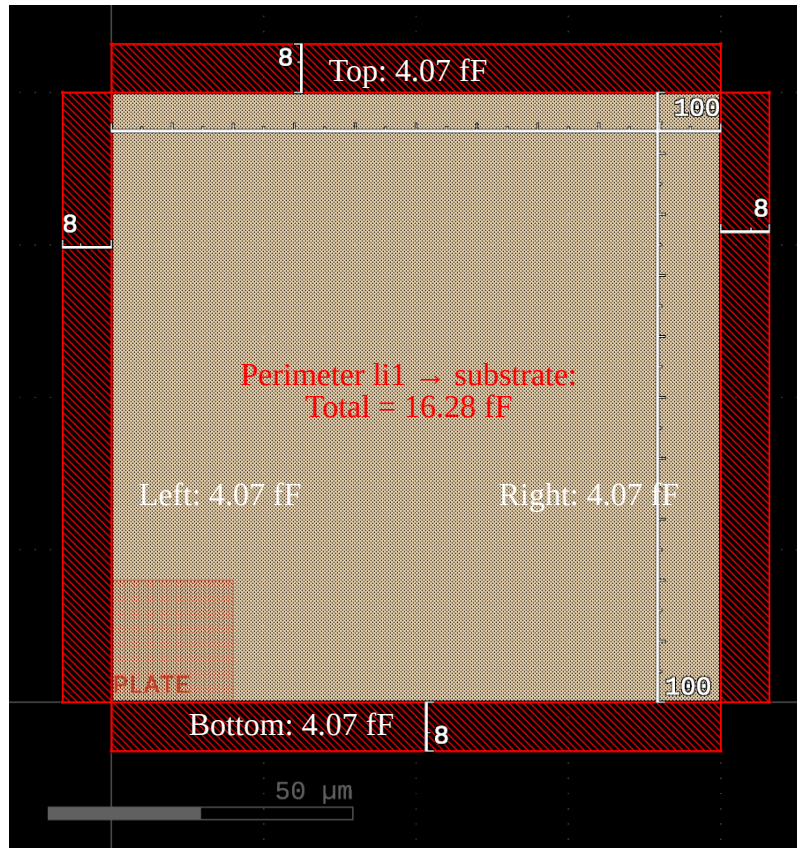

Figure 19: Perimeter (fringe) capacitance li1 to substrate.

Description	Layer Top	Net Top	Layer Bottom	Net Bottom	MAGIC [fF]	KPEX/2.5D [fF]	MAGIC Lines
Fringe (top)	li1	li1	substrate	VSUBS	4.07	4.07	5
Fringe (left)	li1	li1	substrate	VSUBS	4.07	4.07	6
Fringe (right)	li1	li1	substrate	VSUBS	4.07	4.07	7
Fringe (bottom)	li1	li1	substrate	VSUBS	4.07	4.07	8

```
1 Magic 8.3 revision 486 - Compiled on `date`.
```

```
2 -----
```

```
3
```

```
4 CapDebug (extNodeAreaFunc/Area) layer li(90), net li_0_0#, area=400000000 (10000 μm^2) nreg_ca
```

```
5 CapDebug (extNodeAreaFunc/Perimeter/TopSide) layer li(90), net li_0_0#, length=20000 (100 μm),
```

```
6 CapDebug (extNodeAreaFunc/Perimeter/LeftSide) layer li(90), net li_0_0#, length=20000 (100 μm)
```

```
7 CapDebug (extNodeAreaFunc/Perimeter/BottomSide) layer li(90), net li_0_0#, length=20000 (100 μm)
```

```
8 CapDebug (extNodeAreaFunc/Perimeter/RightSide) layer li(90), net li_0_0#, length=20000 (100 μm)
```

```
9 CapDebug (extSetResist): li_0_0# area=400000000 (10000 μm^2) perim=80000 (400 μm)
```

```
10 CapDebug ---
```

## 7.2 Test Pattern sidewall\_20um\_length\_distance\_200nm\_li1

GDS: [https://github.com/martinjankoebler/klayout-pex/blob/main/testdata/designs/sky130A/test\\_patterns/sidewall\\_20um\\_length\\_distance\\_200nm\\_li1.gds.gz](https://github.com/martinjankoebler/klayout-pex/blob/main/testdata/designs/sky130A/test_patterns/sidewall_20um_length_distance_200nm_li1.gds.gz)

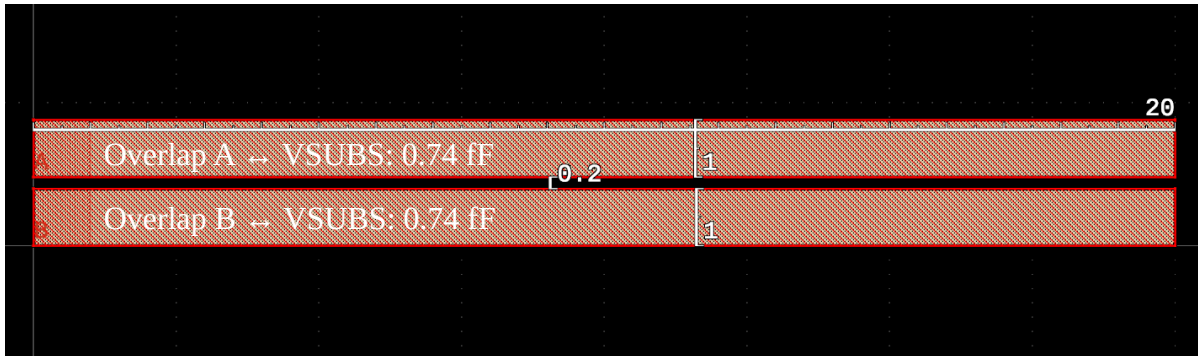

Figure 20: Overlap capacitance of nets on li1.

Table 6: Extracted Parasitic Overlap Capacitances

Description	Layer Top	Net Top	Layer Bottom	Net Bottom	MAGIC [fF]	KPEX/2.5D [fF]	MAGIC Lines
Overlap	li1	A	substrate	VSUBS	0.7398	0.74	4
Overlap	li1	B	substrate	VSUBS	0.7398	0.74	11

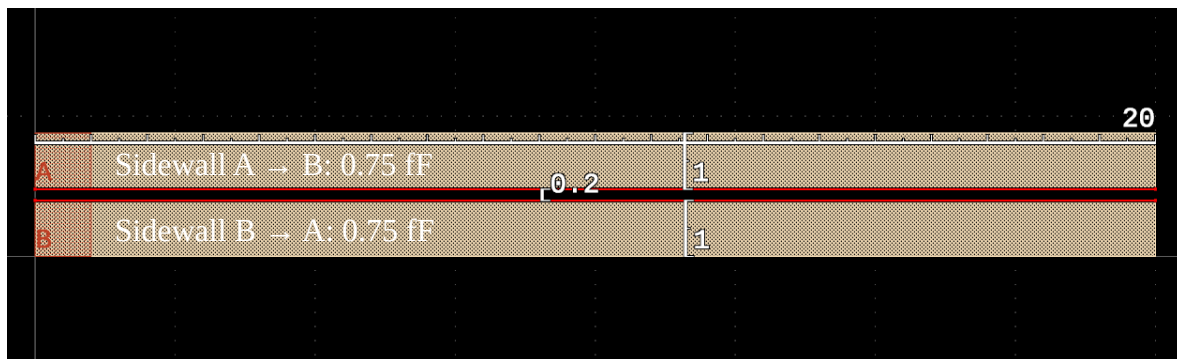

Figure 21: Sidewall capacitance between nets A and B on li1.

Table 7: Extracted Parasitic Sidewall Capacitances

Description	Layer	Net1	Net2	MAGIC [fF]	KPEX/2.5D [fF]	MAGIC Lines
Sidewall	li1	A	B	0.75	0.75	18
Sidewall	li1	B	A	0.75	0.75	21

Table 8: Extracted Parasitic Fringe Capacitances between nets A, B on li1 and substrate

Description	Layer Top	Net Top	Layer Bottom	Net Bottom	MAGIC [fF]	KPEX/2.5D [fF]	MAGIC Lines
Fringe (top)	li1	A	substrate	VSUBS	0.814	0.814	5
Fringe (left)	li1	A	substrate	VSUBS	0.0407	0.041	6

Description	Layer Top	Net Top	Layer Bottom	Net Bottom	MAGIC [fF]	KPEX/2.5D [fF]	MAGIC Lines
Fringe (bottom)	li1	A	substrate	VSUBS	0.814	0.076	7
Fringe (bottom)	li1	A	substrate	VSUBS	-0.7379	—	19
Fringe (right)	li1	A	substrate	VSUBS	0.0407	0.041	8
Fringe (top)	li1	B	substrate	VSUBS	0.814	0.076	12
Fringe (top)	li1	B	substrate	VSUBS	-0.7379	—	22
Fringe (left)	li1	B	substrate	VSUBS	0.0407	0.041	13
Fringe (bottom)	li1	B	substrate	VSUBS	0.814	0.814	14
Fringe (right)	li1	B	substrate	VSUBS	0.0407	0.041	15

```

1 Magic 8.3 revision 486 - Compiled on `date`.
2 -----
3
4 CapDebug (extNodeAreaFunc/Area) layer li(90), net li_0_240#, area=800000 (20 µm^2) nreg_cap +=
5 CapDebug (extNodeAreaFunc/Perimeter/TopSide) layer li(90), net li_0_240#, length=4000 (20 µm),
6 CapDebug (extNodeAreaFunc/Perimeter/LeftSide) layer li(90), net li_0_240#, length=200 (1 µm),
7 CapDebug (extNodeAreaFunc/Perimeter/BottomSide) layer li(90), net li_0_240#, length=4000 (20 µm)
8 CapDebug (extNodeAreaFunc/Perimeter/RightSide) layer li(90), net li_0_240#, length=200 (1 µm),
9 CapDebug (extSetResist): li_0_240# area=800000 (20 µm^2) perim=8400 (42 µm)
10 CapDebug ---
11 CapDebug (extNodeAreaFunc/Area) layer li(90), net li_0_0#, area=800000 (20 µm^2) nreg_cap += 0
12 CapDebug (extNodeAreaFunc/Perimeter/TopSide) layer li(90), net li_0_0#, length=4000 (20 µm), n
13 CapDebug (extNodeAreaFunc/Perimeter/LeftSide) layer li(90), net li_0_0#, length=200 (1 µm), nr
14 CapDebug (extNodeAreaFunc/Perimeter/BottomSide) layer li(90), net li_0_0#, length=4000 (20 µm)
15 CapDebug (extNodeAreaFunc/Perimeter/RightSide) layer li(90), net li_0_0#, length=200 (1 µm), n
16 CapDebug (extSetResist): li_0_0# area=800000 (20 µm^2) perim=8400 (42 µm)
17 CapDebug ---
18 CapDebug (sidewall): A-B (layer li), overlap=4000 (20 µm), sep=40 (0.2 µm), e->ec_cap=12.75 (0
19 CapDebug (obsolete_fringe (blocked)): A == 0.737881 fF ... now A == 1.711319 fF
20     overlapMult=0.003699 (3.699 aF/µm^2) dnear=40 (0.2 µm), snear=0.0935129 (0.000467564 µm),
21 CapDebug (sidewall): A-B (layer li), overlap=4000 (20 µm), sep=40 (0.2 µm), e->ec_cap=12.75 (0
22 CapDebug (obsolete_fringe (blocked)): B == 0.737881 fF ... now B == 1.711319 fF
23     overlapMult=0.003699 (3.699 aF/µm^2) dnear=40 (0.2 µm), snear=0.0935129 (0.000467564 µm),
24 exttospice finished.

```

### 7.3 Test Pattern sideoverlap\_simple\_plates\_li1\_m1

GDS: [https://github.com/martinjankoehler/klayout-pex/blob/main/testdata/designs/sky130A/test\\_patterns/sideoverlap\\_simple\\_plates\\_li1\\_m1.gds.gz](https://github.com/martinjankoehler/klayout-pex/blob/main/testdata/designs/sky130A/test_patterns/sideoverlap_simple_plates_li1_m1.gds.gz)

Table 9: Extracted Parasitic Overlap Capacitances

Description	Layer Top	Net Top	Layer Bottom	Net Bottom	MAGIC [fF]	KPEX/2.5D [fF]	MAGIC Lines
Overlap	li1	li1	substrate	VSUBS	3.699	3.7	7
Overlap	met1	met1	substrate	VSUBS	232.02	232.02	15

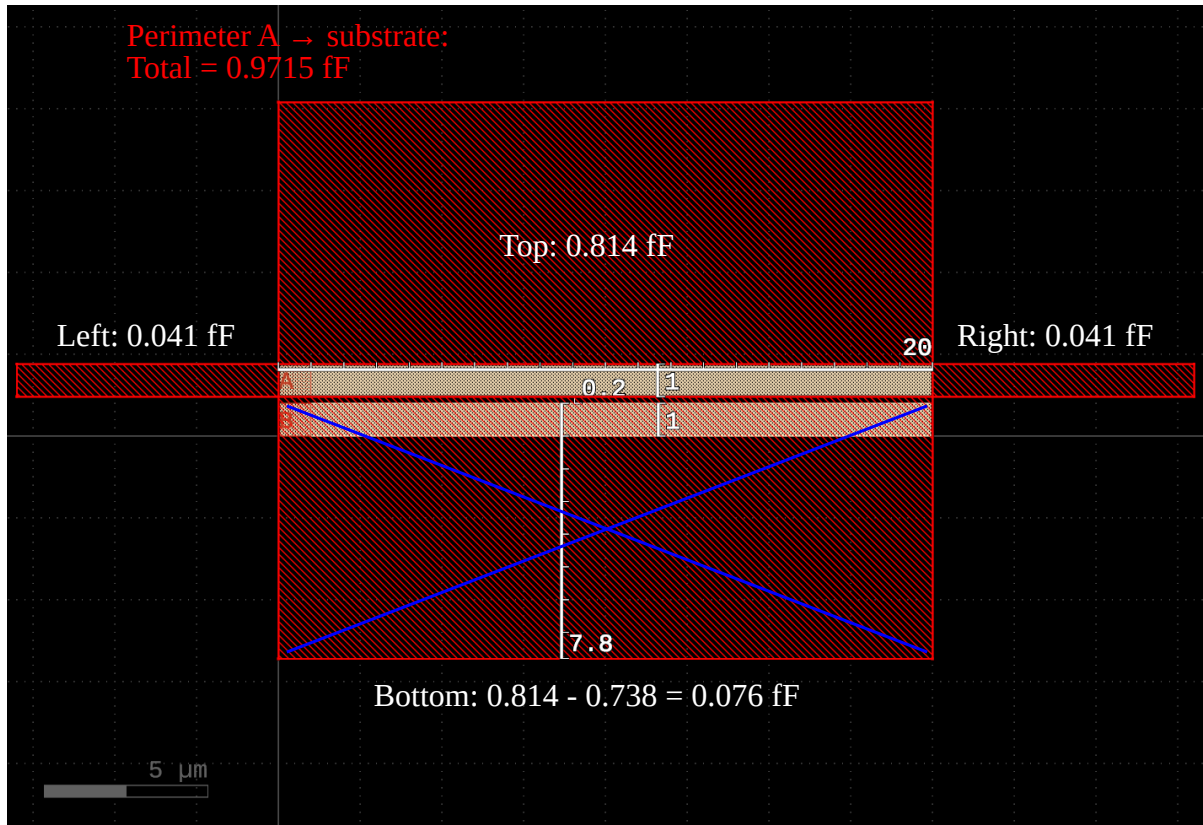

Figure 22: Fringe capacitance between net A and substrate.



Figure 23: Overlap capacitances to substrate.

Figure 24: Fringe capacitances `li1` to substrate.Figure 25: Fringe capacitances `met1` to substrate.

Table 10: Extracted Parasitic Fringe Capacitances between metals and substrate

Description	Layer Top	Net Top	Layer Bottom	Net Bottom	MAGIC [fF]	KPEX/2.5D [fF]	MAGIC Lines
Fringe (top)	li1	li1	substrate	VSUBS	2.035	2.035	9
Fringe (bottom)	li1	li1	substrate	VSUBS	2.035	2.035	11
Fringe (left)	li1	li1	substrate	VSUBS	0.081	0.081	10
Fringe (right)	li1	li1	substrate	VSUBS	0.081	0.081	12
Fringe (top)	met1	met1	substrate	VSUBS	6.0855	6.085	17
Fringe (bottom)	met1	met1	substrate	VSUBS	6.0855	5.927	19
Fringe (bottom)	met1	met1	substrate	VSUBS	-0.1579	—	19
Fringe (left)	met1	met1	substrate	VSUBS	2.4342	2.434	18
Fringe (right)	met1	met1	substrate	VSUBS	2.4342	2.434	20

**i** Note

MAGIC handles shielding differently than KPEX/2.5D, it first assumes no shield exists, and later subtracts portions to arrive at the shielded value. That's why the bold cells differ. Line 15 - 20 accumulate contributions, whereas line 34 subtracts a contribution:

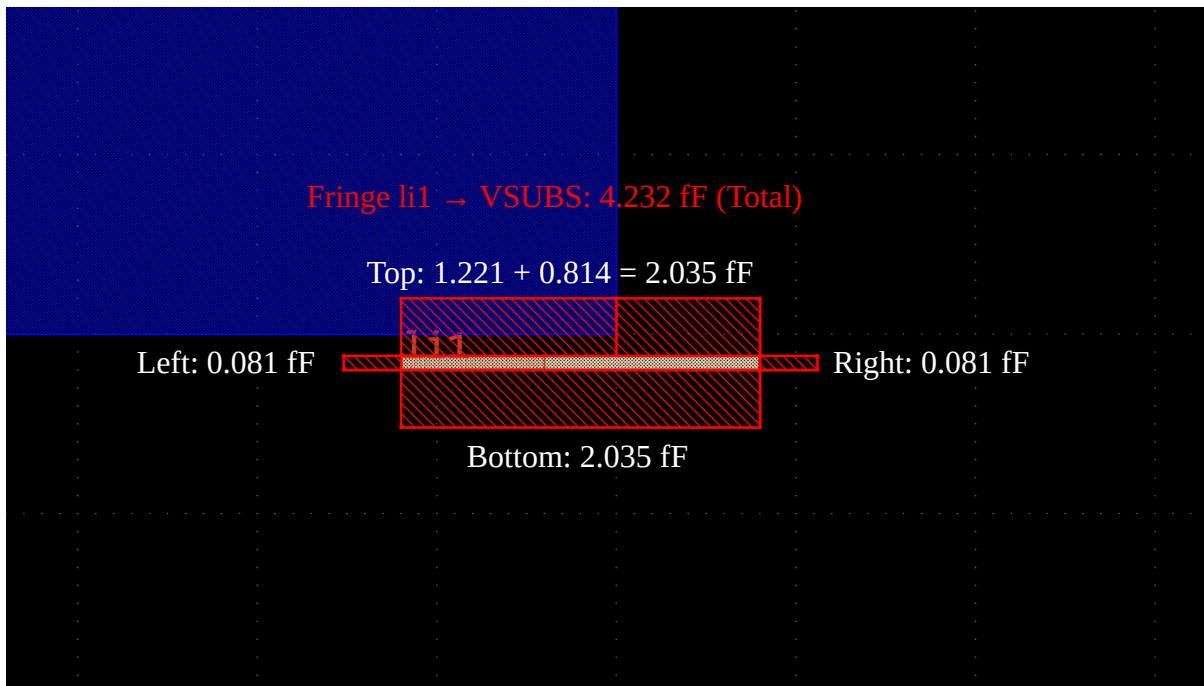
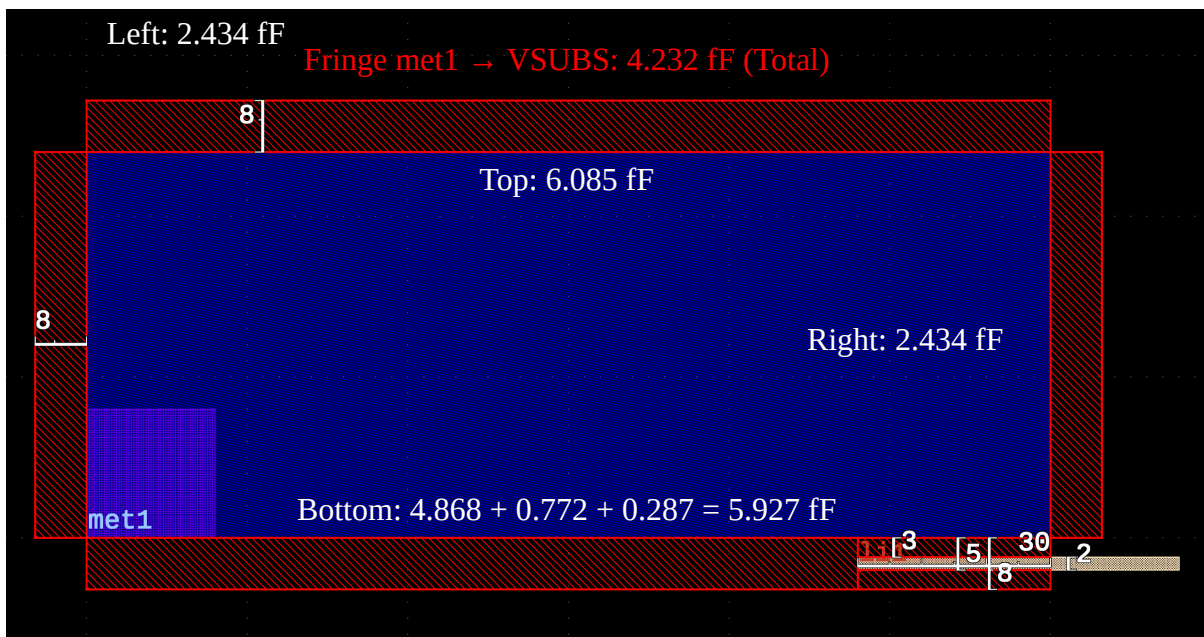
- Line 15: CapDebug (extNodeAreaFunc/Area) layer m1(97), net m1\_10000\_10000#, area=360000000 (9000  $\mu\text{m}^2$ ) nreg\_cap += 232.02 fF
- Line 17: CapDebug (extNodeAreaFunc/Perimeter/TopSide) layer m1(97), net m1\_10000\_10000#, length=30000 (150  $\mu\text{m}$ ), nreg\_cap += 6.0855 fF (now nreg\_cap = 238.105 fF)
- Line 18: CapDebug (extNodeAreaFunc/Perimeter/LeftSide) layer m1(97), net m1\_10000\_10000#, length=12000 (60  $\mu\text{m}$ ), nreg\_cap += 2.4342 fF (now nreg\_cap = 240.54 fF)
- Line 19: CapDebug (extNodeAreaFunc/Perimeter/BottomSide) layer m1(97), net m1\_10000\_10000#, length=30000 (150  $\mu\text{m}$ ), nreg\_cap += 6.0855 fF (now nreg\_cap = 246.625 fF)
- Line 20: CapDebug (extNodeAreaFunc/Perimeter/RightSide) layer m1(97), net m1\_10000\_10000#, length=12000 (60  $\mu\text{m}$ ), nreg\_cap += 2.4342 fF (now nreg\_cap = 249.059 fF)
- Line 34: nreg\_cap -= 0.157966 fF (now nreg\_cap = 248.901 fF)

Comparison:

- KPEX/2.5D:  $4.86834 + 0.77242 + 0.2867 = 5.9275$
- MAGIC:  $6.0855 - 0.157966 = 5.9275$

Table 11: Extracted Parasitic Fringe Capacitances between metals

Description	Layer Top	Net Top	Layer Bottom	Net Bottom	MAGIC [fF]	KPEX/2.5D [fF]	MAGIC Lines
Fringe (top)	li1	li1	met1	met1	0.598	0.06	26
Fringe (bottom)	met1	met1	li1	li1	0.0654	0.065	36

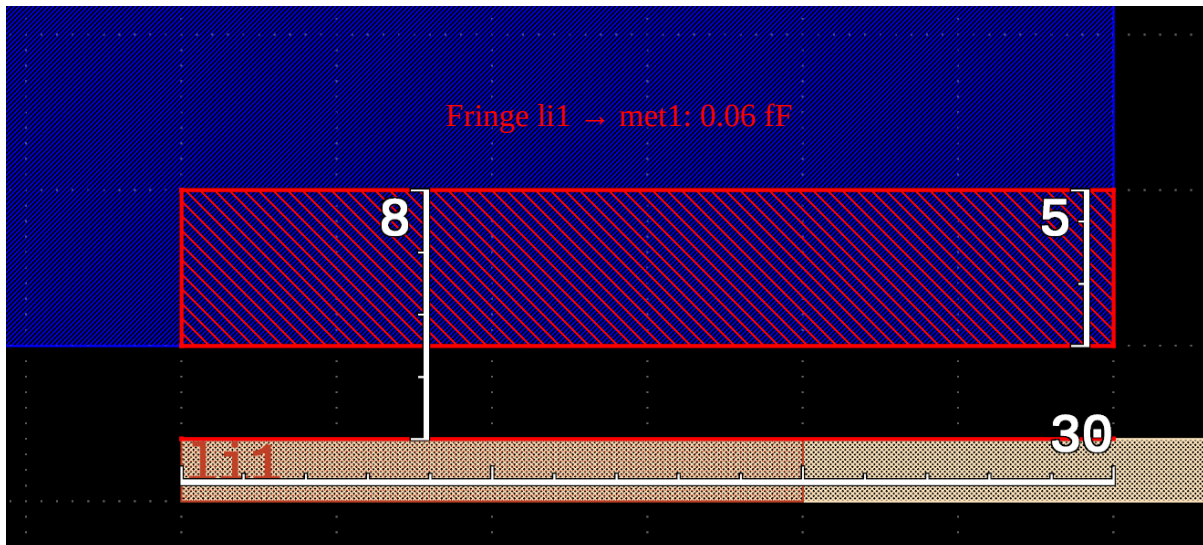

Figure 26: Fringe capacitances li1 to m1.

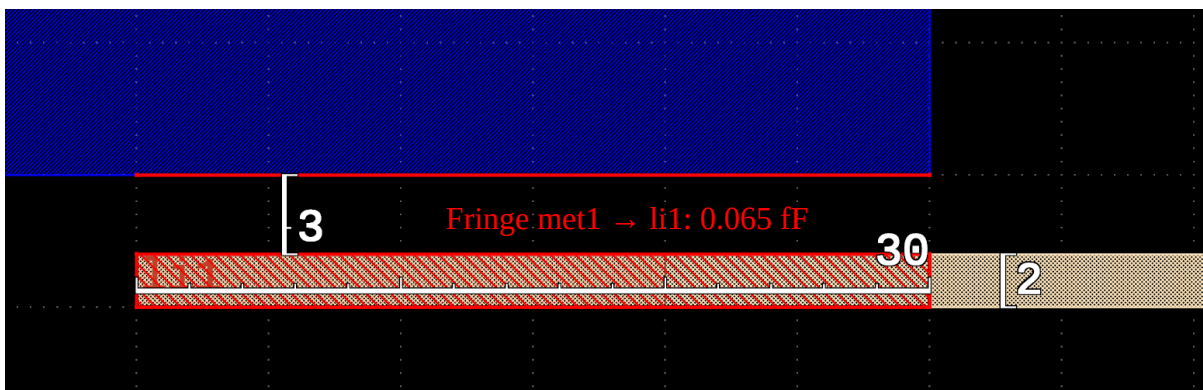

Figure 27: Fringe capacitances m1 to li1.



```

1 Magic 8.3 revision 486 - Compiled on `date`.
2
3 -----
4
5 Extracting sideoverlap_simple_plates_li1_m1 into /Users/martin/Source/klayout-pex/output_sky13
6
7 CapDebug (extNodeAreaFunc/Area) layer li(90), net li_34000_9000, area=4000000 (100 μm^2) nreg_
8
9 CapDebug (extNodeAreaFunc/Perimeter/TopSide) layer li(90), net li_34000_9000, length=10000 (50
10 CapDebug (extNodeAreaFunc/Perimeter/LeftSide) layer li(90), net li_34000_9000, length=400 (2 μ
11 CapDebug (extNodeAreaFunc/Perimeter/BottomSide) layer li(90), net li_34000_9000, length=10000
12 CapDebug (extNodeAreaFunc/Perimeter/RightSide) layer li(90), net li_34000_9000, length=400 (2
13 CapDebug (extSetResist): li_34000_9000 area=4000000 (100 μm^2) perim=20800 (104 μm)
14 CapDebug ---
15 CapDebug (extNodeAreaFunc/Area) layer m1(97), net m1_10000_10000#, area=360000000 (9000 μm^2)
16
17 CapDebug (extNodeAreaFunc/Perimeter/TopSide) layer m1(97), net m1_10000_10000#, length=30000 (
18 CapDebug (extNodeAreaFunc/Perimeter/LeftSide) layer m1(97), net m1_10000_10000#, length=12000
19 CapDebug (extNodeAreaFunc/Perimeter/BottomSide) layer m1(97), net m1_10000_10000#, length=3000
20 CapDebug (extNodeAreaFunc/Perimeter/RightSide) layer m1(97), net m1_10000_10000#, length=12000
21 CapDebug (extSetResist): m1_10000_10000# area=360000000 (9000 μm^2) perim=84000 (420 μm)
22 CapDebug ---
23 CapDebug (extSideOverlapHalo): (li-m1) length=30.000000 μm, mult=0.011420, dnear=3.000000 μm (
24 CapDebug (extSideOverlapHalo) (li-substrate): mult=0.003699, snear=0.730477, sfar=0.893413 (sf
25 CapDebug (extSideOverlapHalo): efflength=1.72351 μm, cap+=0.299029 aF, cap=59.8059 aF, e->ec_c
26 CapDebug (sideoverlaphalo): met1-li1 += 0.059806 fF ... now met1-li1 == 0.059806 fF
27 CapDebug ---
28 CapDebug (extSideOverlapHalo): (m1-li) length=30.000000 μm, mult=0.011420, dnear=3.000000 μm (
29 CapDebug (extSideOverlapHalo) (m1-substrate): mult=0.002578, snear=0.634619, sfar=0.764408 (sf
30 CapDebug (extSideOverlapHalo): efflength=1.0996 μm, cap+=0.327131 aF, cap=65.4263 aF, e->ec_ca
31 CapDebug (extSideOverlapHalo/obsolete_perimcap) layer m1(97), net met1,
32     efflength=3.89366 μm (778.733) = (sfrac(0.129789) - subfrac(0)) * length(30 μm)
33     exts_perimCap[m1][0] = 0.20285
34     nreg_cap -= 0.157966 fF (now nreg_cap = 248.901 fF)
35 CapDebug (obsolete_perimcap): met1 -= 0.157966 fF ... now met1 == 248.901423 fF
36 CapDebug (sideoverlaphalo): met1-li1 += 0.065426 fF ... now met1-li1 == 0.125232 fF

```

## 7.4 Test Pattern r\_single\_wire\_li1

GDS: [https://github.com/martinjankoehler/klayout-pex/blob/main/testdata/designs/sky130A/test\\_patterns/r\\_single\\_wire\\_li1.gds.gz](https://github.com/martinjankoehler/klayout-pex/blob/main/testdata/designs/sky130A/test_patterns/r_single_wire_li1.gds.gz)

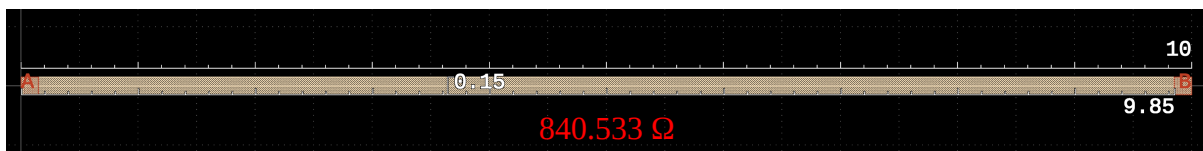

Figure 28: Resistance of a single wire on li1.

- Wire length  $L = 9.85 \mu\text{m}$
- Wire height  $H = 0.15 \mu\text{m}$
- Layer is li1

- Parasitic Table Coefficient  $R_{coeff}(li1) = 12800\text{ m}\Omega$

If we apply the formula illustrated in Section 5.8.1, we get

$$R_{wire} = \frac{L}{H} * R_{coeff}$$

$$R_{wire} = \frac{9.85\ \mu\text{m}}{0.15\ \mu\text{m}} * 12800\ \text{m}\Omega = 84053\ \text{m}\Omega = 840.53\ \Omega$$

```

1 Magic 8.3 revision 486 - Compiled on `date`.
2 -----
3 ...
4 Warning: Ports "A" and "B" are electrically shorted.
5
6 Location is (1970, -15); drivepoint (1970, -15)
7 Location is (0, -15); drivepoint (0, -15)
8
9 ResCalcEastWest: A (0, -0.075) <-> B (9.85, -0.075) @ li
10     exts_sheetResist[li]=12800, length=9.85, height=0.15, resistor->rr_value = 840533 mΩ
11 ResCalcEastWest: A (0, -0.075) <-> B (9.85, -0.075) @ li
12     exts_sheetResist[li]=12800, length=9.85, height=0.15, resistor->rr_value = 840533 mΩ
13 Total Nets: 2

```

#### **i** Note

MAGIC recognizes that ports A and B are shorted. The purpose of these test patterns is to look at minimized problems in isolation, like the resistance of the wire here. They are not realistic examples, so it appears to be a bug in that corner case, that the resistance is reported twice.

## 7.5 Test Pattern r\_contact\_1x1\_minsize\_mcon

GDS: [https://github.com/martinjankoehler/klayout-pex/blob/main/testdata/designs/sky130A/test\\_patterns/r\\_contact\\_1x1\\_minsize\\_mcon.gds.gz](https://github.com/martinjankoehler/klayout-pex/blob/main/testdata/designs/sky130A/test_patterns/r_contact_1x1_minsize_mcon.gds.gz)

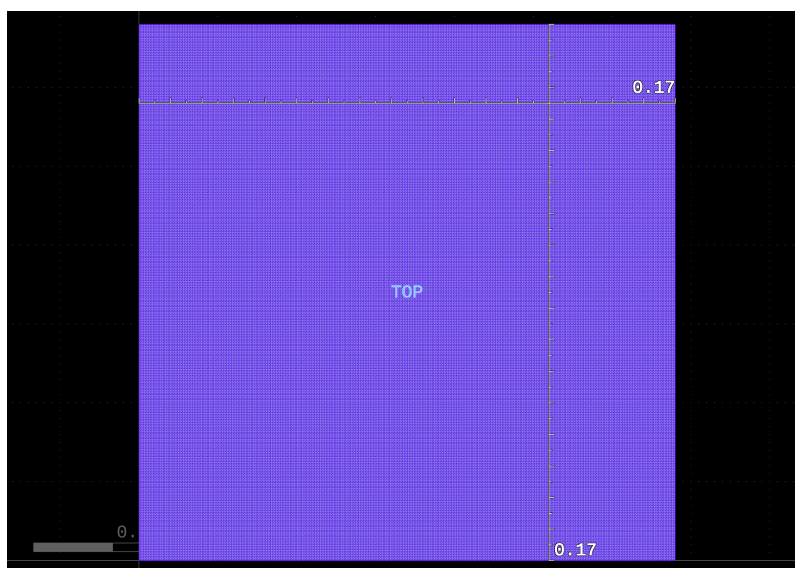

Figure 29: Resistance of a minimum sized via on mcon.

- Layers:

- Top Layer: `met1`
- Via: `mcon`
- Bottom Layer: `li1`
- Design rules:
  - Via width:  $viawidth = 0.17 \mu m$
  - Via spacing:  $spacing = 0.19 \mu m$
  - Via border:  $border = 0.0 \mu m$
- Parasitic Table Coefficient  $R_{coeff}(mcon) = 9300 m\Omega$
- Drawn via:
  - $w = 0.17 \mu m$
  - $h = 0.17 \mu m$

If we apply the formula illustrated in Section 5.8.2, we get

$$n_x = 1 + \left\lfloor \frac{w - (viawidth + 2 * border)}{viawidth + spacing} \right\rfloor$$

$$n_x = 1 + \left\lfloor \frac{0.17 \mu m - (0.17 + 2 * 0.0) \mu m}{0.17 \mu m + 0.19 \mu m} \right\rfloor = 1$$

$$n_y = 1 + \left\lfloor \frac{h - (viawidth + 2 * border)}{viawidth + spacing} \right\rfloor$$

$$n_y = 1 + \left\lfloor \frac{0.17 \mu m - (0.17 + 2 * 0.0) \mu m}{0.17 \mu m + 0.19 \mu m} \right\rfloor = 1$$

$$R_{via} = \frac{R_{coeff}}{n_x * n_y} \left[ \frac{m\Omega}{\text{via count}} \right]$$

$$R_{via} = \frac{9300 m\Omega}{1 * 1} = 9300 m\Omega = 9.3 \Omega$$

```

1 Magic 8.3 revision 486 - Compiled on `date`.
2 -----
3 ...
4 Warning: Ports "TOP" and "BOT" are electrically shorted.
5 Location is (0, 0); drivepoint (0, 0)
6 Location is (0, 0); drivepoint (0, 0)
7
8 ResDoContacts: (null) (0.085, 0.085) <-> (null) (0.085, 0.085) @ v0
9   W = 0.17 μm, H = 0.17 μm
10  exts_viaResist[v0]=9300, viawidth=0.17 μm, spacing=0.19 μm, border=0 μm
11  squaresx=1, squaresy=1, resistor->rr_value = 9300 mΩ

```

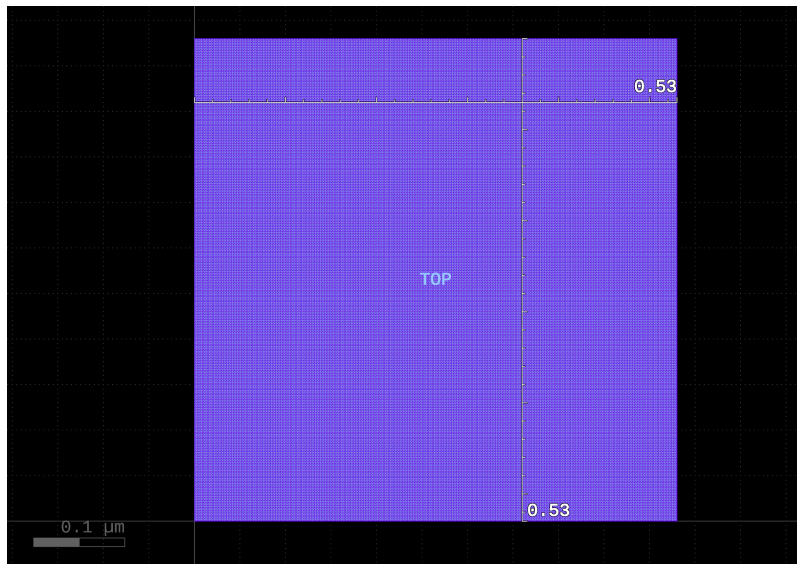

Figure 30: Resistance of a minimum sized 2x2 via on mcon.

## 7.6 Test Pattern `r_contact_2x2_minsize_mcon`

GDS: [https://github.com/martinjankoehler/klayout-pex/blob/main/testdata/designs/sky130A/test\\_patterns/r\\_contact\\_2x2\\_minsize\\_mcon.gds.gz](https://github.com/martinjankoehler/klayout-pex/blob/main/testdata/designs/sky130A/test_patterns/r_contact_2x2_minsize_mcon.gds.gz)

- Layers:
  - Top Layer: `met1`
  - Via: `mcon`
  - Bottom Layer: `li1`
- Design rules:
  - Via width:  $viawidth = 0.17 \mu m$
  - Via spacing:  $spacing = 0.19 \mu m$
  - Via border:  $border = 0.0 \mu m$
- Parasitic Table Coefficient  $R_{coeff}(mcon) = 9300 m\Omega$
- Drawn via:
  - $w = 0.53 \mu m$
  - $h = 0.53 \mu m$

If we apply the formula illustrated in Section 5.8.2, we get

$$n_x = 1 + \left\lfloor \frac{w - (viawidth + 2 * border)}{viawidth + spacing} \right\rfloor$$

$$n_x = 1 + \left\lfloor \frac{0.53 \mu m - (0.17 + 2 * 0.0) \mu m}{0.17 \mu m + 0.19 \mu m} \right\rfloor = 1 + \lfloor 1.0 \rfloor = 2$$

$$n_y = 1 + \left\lfloor \frac{h - (viawidth + 2 * border)}{viawidth + spacing} \right\rfloor$$

$$n_y = 1 + \left\lfloor \frac{0.53 \mu m - (0.17 + 2 * 0.0) \mu m}{0.17 \mu m + 0.19 \mu m} \right\rfloor = 1 + \lfloor 1.0 \rfloor = 2$$

$$R_{via} = \frac{R_{coeff}}{n_x * n_y} \left[ \frac{m\Omega}{\text{via count}} \right]$$

$$R_{via} = \frac{9300 m\Omega}{2 * 2} = 2325 m\Omega = 2.325 \Omega$$

```
1 Magic 8.3 revision 486 - Compiled on `date`.
2 -----
3 ...
4 Warning: Ports "TOP" and "BOT" are electrically shorted.
5 ...
6 ResDoContacts: (null) (0.265, 0.265) <-> (null) (0.265, 0.265) @ v0
7   W = 0.53 μm, H = 0.53 μm
8   exts_viaResist[v0]=9300, viawidth=0.17 μm, spacing=0.19 μm, border=0 μm
9   squaresx=2, squaresy=2, resistor->rr_value = 2325 mΩ
```

## 8 Appendix

### References

- Di Lorenzo, Enrico. 2019. “FasterCap Embedded Help.” 2019. <https://www.fastfieldsolvers.com/Download/FasterCapHelp.chm>.
- . 2023. “The Maxwell Capacitance Matrix: White Paper WP110301. Revision 03.” 2023. [https://www.fastfieldsolvers.com/Papers/The\\_Maxwell\\_Capacitance\\_Matrix\\_WP110301\\_R03.pdf](https://www.fastfieldsolvers.com/Papers/The_Maxwell_Capacitance_Matrix_WP110301_R03.pdf).
- Edwards, R. Timothy. 2022. “Whom Do You Trust? Validating Process Parameters for Open-Source Tools.” [https://wiki.f-si.org/index.php?title=Whom\\_do\\_you\\_trust%3F:\\_Validating\\_process\\_parameters\\_for\\_open-source\\_tools](https://wiki.f-si.org/index.php?title=Whom_do_you_trust%3F:_Validating_process_parameters_for_open-source_tools).
- . 2023a. “Full r-c Extraction in Magic (Presentation Slides).” [https://lists.chipsalliance.org/g/analog-wg/attachment/99/0/AWG\\_040423\\_Tim\\_Edwards\\_chips\\_alliance\\_slides.pdf](https://lists.chipsalliance.org/g/analog-wg/attachment/99/0/AWG_040423_Tim_Edwards_chips_alliance_slides.pdf).
- . 2023b. “Full r-c Extraction in Magic (Presentation Video).” <https://www.youtube.com/watch?v=4d2mtiEHHeo>.
- Maxwell, James Clerk. 1873. *A Treatise on Electricity and Magnetism*. Vol. 1. Clarendon Press.
- Nagel, Laurence W. 1975. “SPICE2: A Computer Program to Simulate Semiconductor Circuits.” PhD thesis, EECS Department, University of California, Berkeley. <http://www2.eecs.berkeley.edu/Pubs/TechRpts/1975/9602.html>.